



INSTALLATION MANUAL ECLIPSE XL ARMS AND CANOPY

This publication covers models:

RV

- Eclipse XL w/ Single Switch Control



Read this manual before installing or using this product. Failure to follow the instructions and safety precautions in this manual can result in personal injury and/or cause the product to not operate properly.

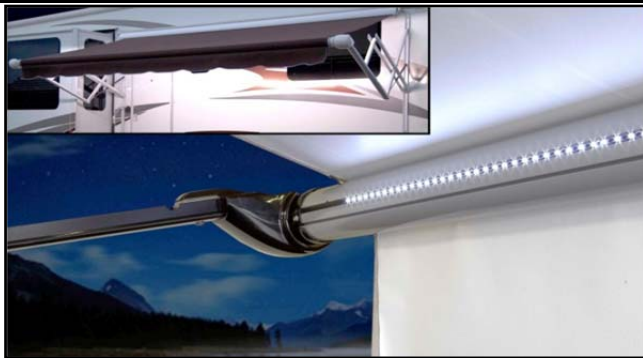

LED Lighting

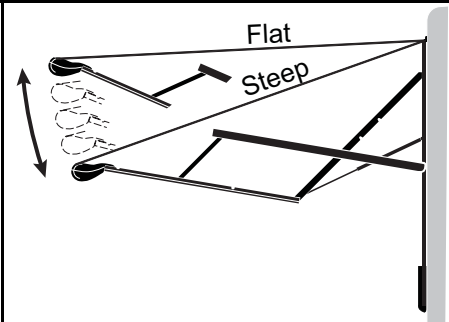

Adjustable Pitch

E0069

TABLE OF CONTENTS

Product Overview	1
Eclipse Patio Awning Specifications:.....	1
Component Checklist.....	2
Installation	3
Required Pre-Installation Preparation.....	3
Installing an Awning Rail.....	3
Assembling the Awning	4
Mounting the Awning	5
Electrical	6
Single Switch Installation	6
Final Assembly	8
Attaching the Fascia and Bottom Cover	8
Securing the Fabric.....	8
Removing the Temporary Assembly Pins.....	8
Installing the Tractioners.....	9
Optional LED's	10
Wire Routing.....	10
Switch Installation	11
Adjusting the Spring Tension	12

PROPRIETARY STATEMENT

The Eclipse XL Patio Awning is a product of Carefree of Colorado, located in Broomfield, Colorado, USA. The information contained in or disclosed in this document is considered proprietary to Carefree of Colorado. Every effort has been made to ensure that the information presented in the document is accurate and complete. However, Carefree of Colorado assumes no liability for errors or for any damages that result from the use of this document.

The information contained in this manual pertains to the current configuration of the models listed on the title page. Earlier model configurations may differ from the information given. Carefree of Colorado reserves the right to cancel, change, alter or add any parts and assemblies, described in this manual, without prior notice.

Carefree of Colorado agrees to allow the reproduction of this document for use with Carefree of Colorado products only. Any other reproduction or translation of this document in whole or part is strictly prohibited without prior written approval from Carefree of Colorado.

Safety Information



This is the safety alert symbol. It is used to alert individuals to potential personal injury hazards. Obey all safety messages that follow this symbol to avoid possible personal injury or death.



Indicates a hazardous situation, which if not avoided, could result in death or serious bodily injury.



Indicates a hazardous situation, which if not avoided, may result in minor or moderate bodily injury.



Indicates a situation that may result in equipment-related damage.

General Safety:



This product can expose you to chemicals including Di-isodecyl phthalate (DIDP), Vinyl Chloride and Formaldehyde, which are known to the state of California to cause cancer or birth defects or other reproductive harm. For more information visit www.P65warnings.ca.gov



Shock Hazard. Always disconnect battery or power source before working on or around the electrical system.



Always wear appropriate safety equipment (i.e. goggles).



Always use appropriate lifting devices and/or helpers when lifting or holding heavy objects.

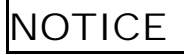

When using fasteners, do not over tighten. Soft materials such as fiberglass and aluminum can be "stripped out" and lose the ability to grip and hold.

PRODUCT OVERVIEW

- The unique "scissor" style arms eliminate the need for vertical ground supports.
- Easy to use 6 position pitch adjustment. The pitch can be left in any position and the Eclipse will roll up completely! When the awning is rolled back out, it rolls out to the pitch setting previously set.
- Worm gear style motor is billow proof - eliminates the need for travel locks.

Eclipse Patio Awning Specifications:

Length	12' - 21' [366 - 640cm]		
Extension:	9' [274cm]	Drop @ Min. Pitch: 13.5" [34.3cm]	Drop @ Max. Pitch: 45" [114.3cm]
Values are approximate, actual dimensions may vary with specific installations.			
Extend Actuation:	Gas Shock		
Retract Actuation	Motorized roll up w/ supplemental spring tension		
Power Requirements:	12VDC (operating range 10VDC to 14VDC)	Circuit Rating: 15 amp	
Power Source:	Motor and controls are routed and hardwired into the vehicle's 12V system		
Emergency Retract:	Electrical override system (external power source)		
Color:	Hardware:	White, Black	
	Fabric:	Heavy Duty Vinyl or Acrylic Fabric with Alumaguard or Uniguard (refer to sales literature for colors)	
	Fabric Wrap:	Vinyl Weatherguard (vinyl only) or Metal Wraps: Alumaguard or Uniguard	

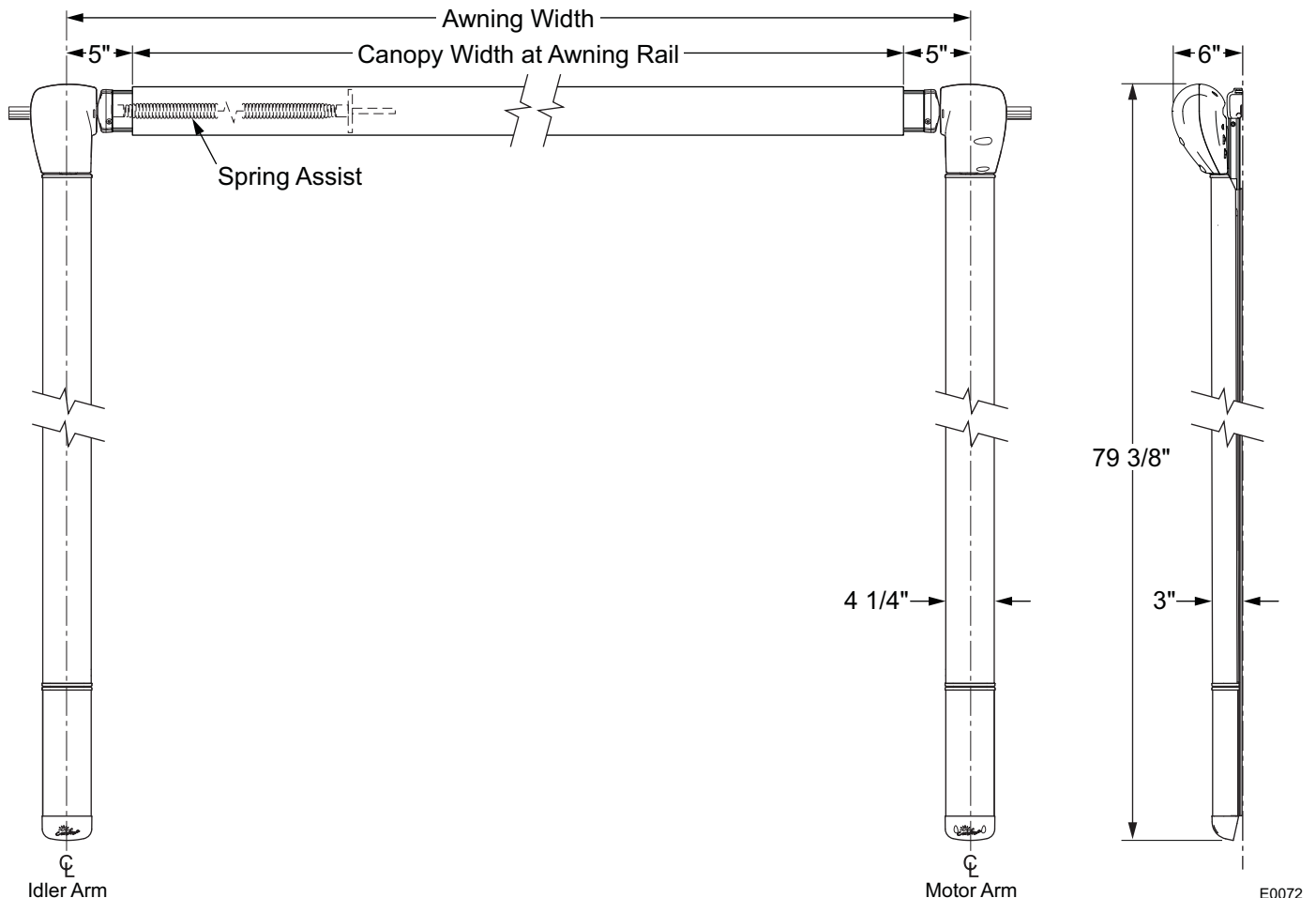

E0072

COMPONENT CHECKLIST

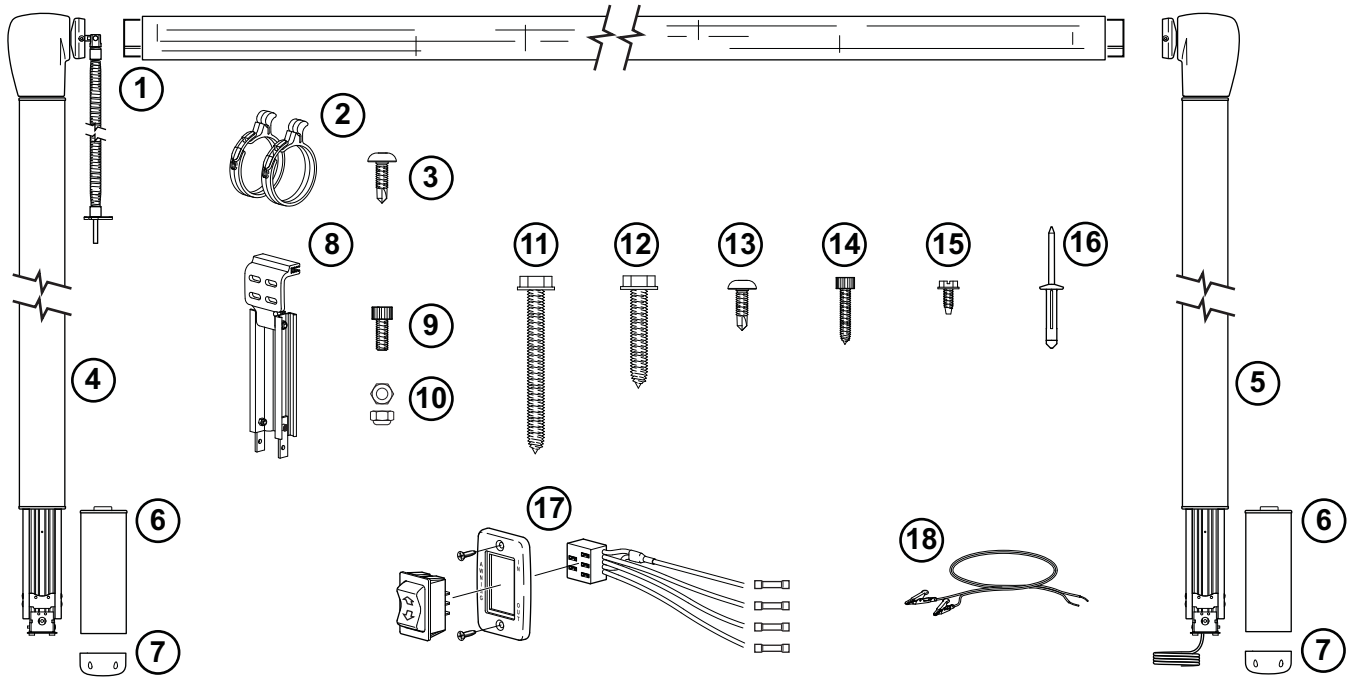

E0071

<input checked="" type="checkbox"/>	Item	Description		Qty	Note
<input type="checkbox"/>	1	Roller Tube Assembly		1	
<input type="checkbox"/>	2	Tractioner		2	2
<input type="checkbox"/>	3	Screw, Truss Head, SQ Drive	#10 x 5/8	2	2
<input type="checkbox"/>	4	LH Arm Assy, Idler		1	
<input type="checkbox"/>	5	RH Arm Assy, Motorized		1	
<input type="checkbox"/>	6	Fascia Assy		2	
<input type="checkbox"/>	7	Bottom Cover		2	
<input type="checkbox"/>	8	Rail Extension Kit		1	3
<input type="checkbox"/>	9	Screw, SHC	#10 x 1/2	4	3
<input type="checkbox"/>	10	Nylock Nut	10-32	4	3
<input type="checkbox"/>	11	Screw, Lag	1/4 x 2 1/2	4	
<input type="checkbox"/>	12	Screw, Lag	1/4 x 1 1/2	8	
<input type="checkbox"/>	13	Screw, Truss Head, SQ Drive	#10 x 5/8	4	
<input type="checkbox"/>	14	Screw, SHC, Self-Tapping	#8 x 3/4	4	
<input type="checkbox"/>		Screw, HWHC	#6 x 3/8	2	
<input type="checkbox"/>		Rivet, Moly	7/32	4	
<input type="checkbox"/>		Switch Kit, Single Switch		1	4
<input type="checkbox"/>		Jumper Cable		1	5

- Notes:
- Awning configuration is specified at time of order, including awning length, fabric, color and electronics. Check awning assembly against original purchase order.
 - Screws and Tractioners are furnished with roller tube assemblies equipped with optional Alumaguard/Uniguard.
 - Rail Extension kit includes hardware for two arms (items 8, 9,10).
 - Installers may choose to furnish the control switch (item 13). The switch must be a DC polarity reversing switch with dynamic brake.
 - Place Jumper Cable (item 14) with RV owner information.

INSTALLATION

REQUIRED PRE-INSTALLATION PREPARATION

1. Park the vehicle on a flat surface and level the unit.
2. If this is an upgrade for a manual patio awning, follow the awning manufacturer's instructions and remove the awning from the coach including the roller tube and canopy.
 - 2.1. Remove all brackets.
 - 2.2. Plug and seal all mounting holes. The new Eclipse arms may not match the locations of the old awning arms.
 - 2.3. Remove the roller tube from the arms and on a flat clean surface, roll the fabric onto the roll bar.
 - 2.4. If the canopy is equipped with Alumaguard, remove the tractioners and set aside. These will be reinstalled after the new awning assembly is installed.
3. Check where the awning arms will be installed. The arms fit snug to the side of the vehicle and must not cover or interfere with exhaust vents, lights etc.
4. If there is an awning rail installed, check that the awning rail runs the full length of the awning. Please refer to the note under "Installing an Awning Rail" before proceeding.
5. Refer to the important note on page 6 about the required positioning of the centerline of the roll bar.

INSTALLING AN AWNING RAIL

NOTE: For canopies WITHOUT Alumaguard or Uniguard: If the vehicle already has a full-length awning rail installed, skip to step 5.

For Alumaguard and Uniguard installations: If the existing awning rail is incorporated into the coach trim or a drip rail, it will be necessary to mount a standard awning rail flat on the coach wall. The awning rail and arms must be positioned so that any existing trim does not interfere with the Alumaguard or Uniguard's "Flex Connect" or the awning arm when in the closed position.

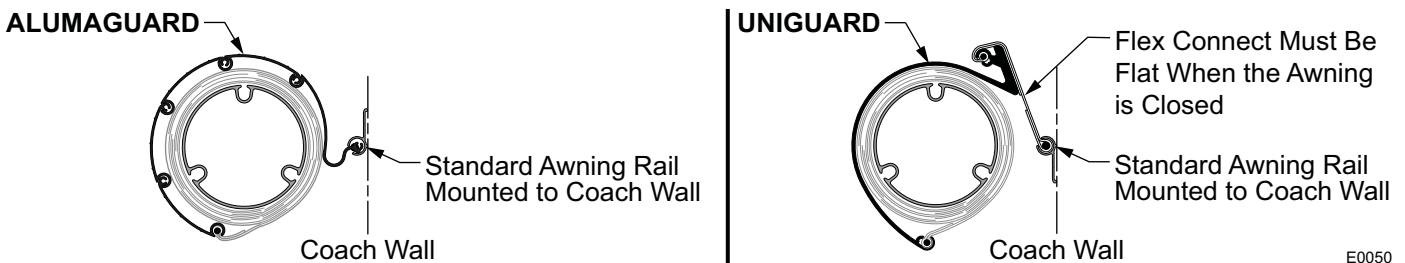

E0050

1. Determine the optimum positioning of the awning so that the arms will not interfere with the door frame or light fixtures. The centerline of the rail should be above the door opening a minimum of 6" for vinyl and 7" for Alumaguard/Uniguard. After determining mounting position, mark the position with a chalk line.
2. Awning rail must be level.
3. Seal the back of the rail with silicone sealant or putty tape.
4. Align the awning rail onto the wall and secure with #10 x 3/4" screws. Use all the attach holes in the rail.

NOTICE Make sure the screws are securely mounted to the structural frame of the vehicle.

5. Use a screwdriver to spread open one end of the awning rail on the installation side.
6. File any sharp edges or burrs from the end of the rail. This will help protect the awning fabric from damage during installation.
7. Spray inside the awning rail track with silicone lubricant.

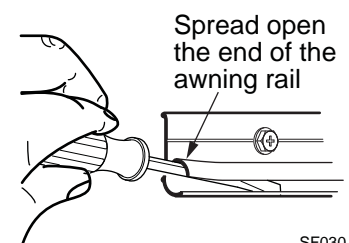

SF030

ASSEMBLING THE AWNING

1. Decide on the location of the switch to determine the cable routing.
2. If the motor cable is to be routed through the RV wall at the bottom of the arm, no modification is required. Go to step 3.
3. If the motor cable is to be routed through the RV wall at the top of the arm:
 - 3.1. Remove the plastic wrap at the top of the motorized arm. Partially open the arm being careful to not let the arm extend more than 6".

NOTE: The arm is under tension from the gas shock located in the arm.
 - 3.2. Pull the cable out of the slot in the rear of the back channel and pull the cables out of the hole in the top of the channel.
 - 3.3. Secure the top of the arm in the closed position using a plastic wrap or equivalent.

NOTICE During assembly and installation, The arm assemblies must remain perpendicular to the roller assembly. Failure to handle the arms carefully can bend the drive shaft.

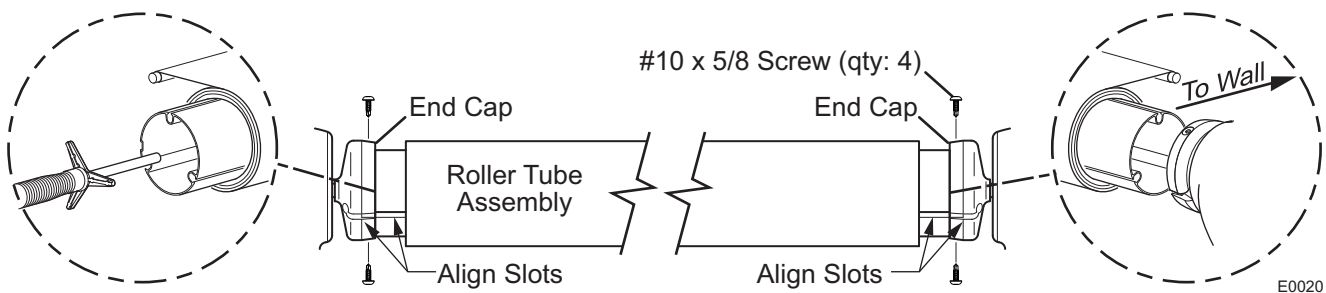

4. Align the roller assembly with the end cap on the motorized arm assembly. Rotate the end cap until the slot in the cap aligns with the empty slot in the roller assembly, and then press the roller assembly fully into the cap. The end cap must seat squarely over the end of the roller assembly when complete.

NOTE: The roller assembly must be oriented with the fabric going over the roller toward the mounting surface.

5. Secure the end cap to the roller tube assembly using two #10 square-drive screws.
6. On the idler side, insert the spring into the roller tube.
7. Rotate the end cap until the slot in the cap aligns with the empty slot in the roller assembly, and then press the roller assembly fully into the cap and secure using two #10 square-drive screws.
8. Attach the rail extension assembly:
 - 8.1. At the top of the arms, remove the rail caps.
 - 8.2. Attach the rail extension to the rail as shown.

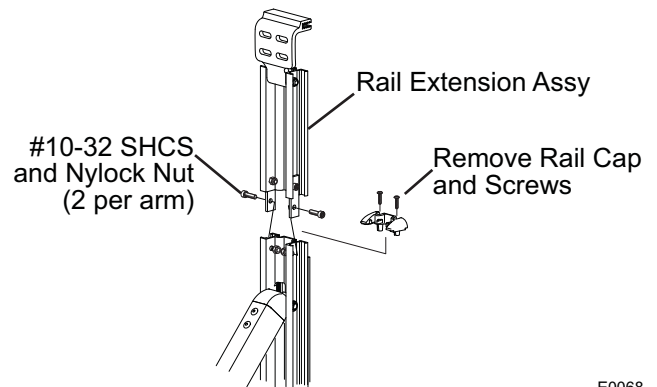

MOUNTING THE AWNING



CAUTION It is recommended that at least three people install the awning due to its size and weight.

NOTE: For the bottom 2 mounting holes: if mounting into structure, use the 1/4 x 1 1/2 screws; if not attaching into structure, use the moly rivets.

1. Check the location where the awning is to be mounted. Ensure that the awning will not interfere with other equipment on the vehicle, such as a slide out room, light fixtures, exhaust vents etc.
2. On the awning rail, mark the location of the centerline of the arm assemblies.
3. Unroll the canopy one wrap.

NOTICE Do not unroll the canopy more than 1 to 1 1/2 wraps. No pre-tension is required on the spring at rest (closed). Excessive unwrap will cause the spring to be put in reverse tension at close, causing the awning to not close properly.

4. With one person holding each arm, the third person should thread the polyrod (the plastic rod on the edge of the fabric) into the awning rail, starting at one end. Carefully move across the vehicle, gently pulling the fabric into the rail, until the awning is in the pre-determined location.

NOTE: While the awning fabric is fairly robust, care must be taken not to snag it on the awning rail.

5. Butt the top of the rear channel against the awning rail as shown.

6. Drill a pilot hole at the first mounting hole for the RH (motorized) arm

6.1. If mounting into structure: Use 1/4 x 1 1/2" screws. Requires a 5/32" pilot hole.

6.2. If mounting to the outer skin only: Use 3/16" moly rivets. Requires a 7/32" (#4) hole.

7. Confirm that the arm is perpendicular to the awning rail and attach the arm at the second mounting point.

8. Repeat for the idler arm.

9. Hold the awning closed and carefully remove the plastic wraps at the top of the arms. The awning will open a few inches.

10. Open the awning about 18" or until the top mounting holes on the arms are visible. To open

10.1. Temporarily connect the ends of the motor wires to a 12V-14V source (i.e. drill battery). If the awning does not begin to move, reverse the leads.

10.2. Remove the battery after the awning is open.

11. Attach the top of the arms using two (2) 1/4 x 2 1/2 lag screws through the top brackets for each arm.

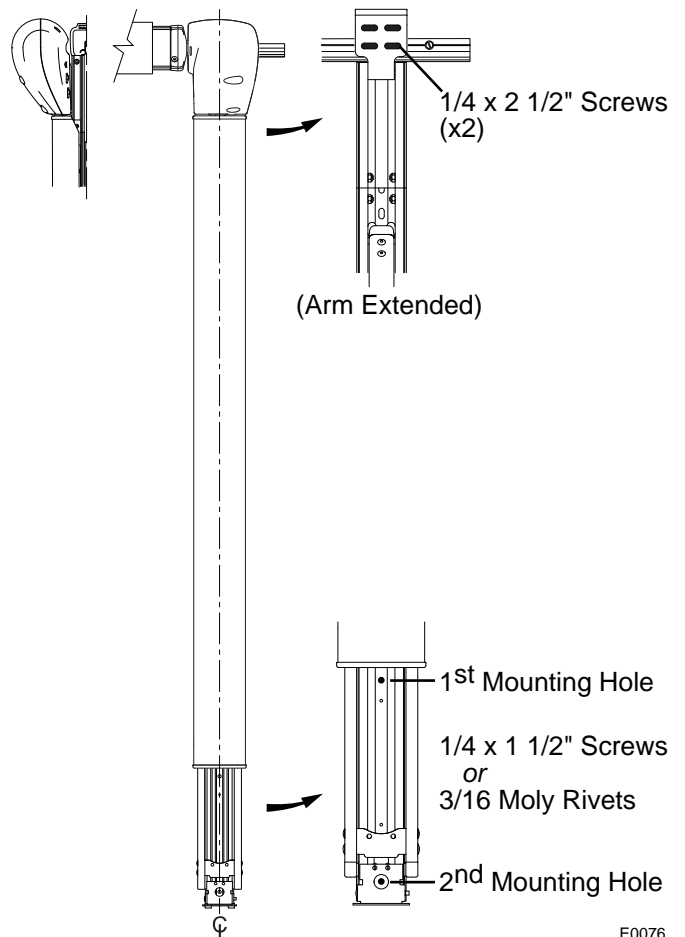

E0076

ELECTRICAL



WARNING Shock Hazard. Always disconnect battery or power source before working on or around the electrical system.

- Notes:**
1. Failure to follow the wiring instructions in this publication may void the motor warranty.
 2. DO NOT wire two or more motors to one switch—No parallel wiring.
 3. All wiring must conform to NEC (National Electrical Code) and local codes.
 4. OEM's may choose to furnish the control switch. The switch must be a DC polarity reversing switch with dynamic brake.

The standard Eclipse Patio Awning comes with a single switch. The single switch configuration has one interior extend/retract switch.

SINGLE SWITCH INSTALLATION

1. Determine the final location of the switch and mark the location.
2. Drill a 5/16" hole through the vehicle wall for the motor cable.
3. Route the cable through the holes to the location of the switch panel.
4. Seal the cable and hole using a silicone sealant.
5. At the switch location, cut a rectangular hole 1.25" (3.2cm) x 1.88" (4.8cm) through the mounting surface.

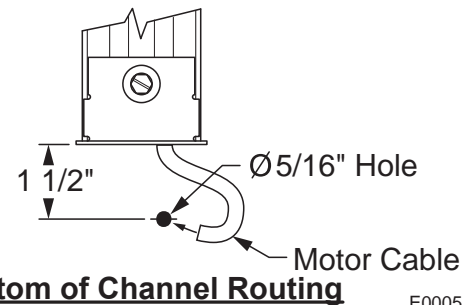
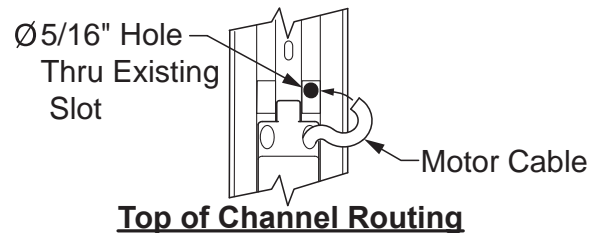

E0005

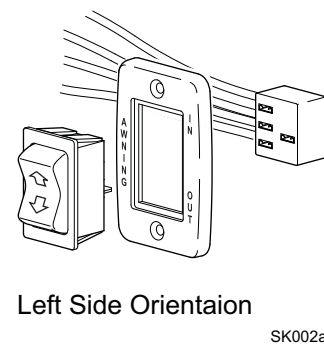
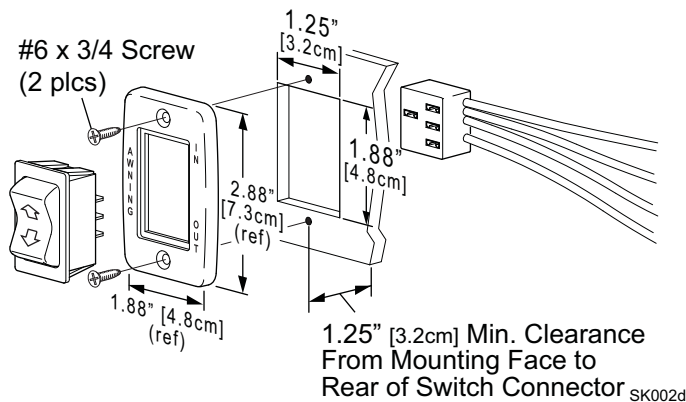

6. Determine the switch orientation:
 - 6.1. The wires of the connector extend from the side of the switch with 3 terminals on the back.
 - 6.2. For wire routing on the right side of the switch as shown in Details A and B, orient the switch with the 3 terminals on the right.
 - 6.3. For wire routing on the left side of the switch as shown in Detail C, orient the switch with the 3 terminals on the left.
 - 6.4. Push the switch into the faceplate until the tabs on the switch “click” into place behind the faceplate. Ensure that the switch and faceplate are oriented so that the lettering is up and the wires are oriented as desired.
 - 6.5. Set switch aside.

7. Route the awning motor wires through the switch hole and attach to the switch connector:

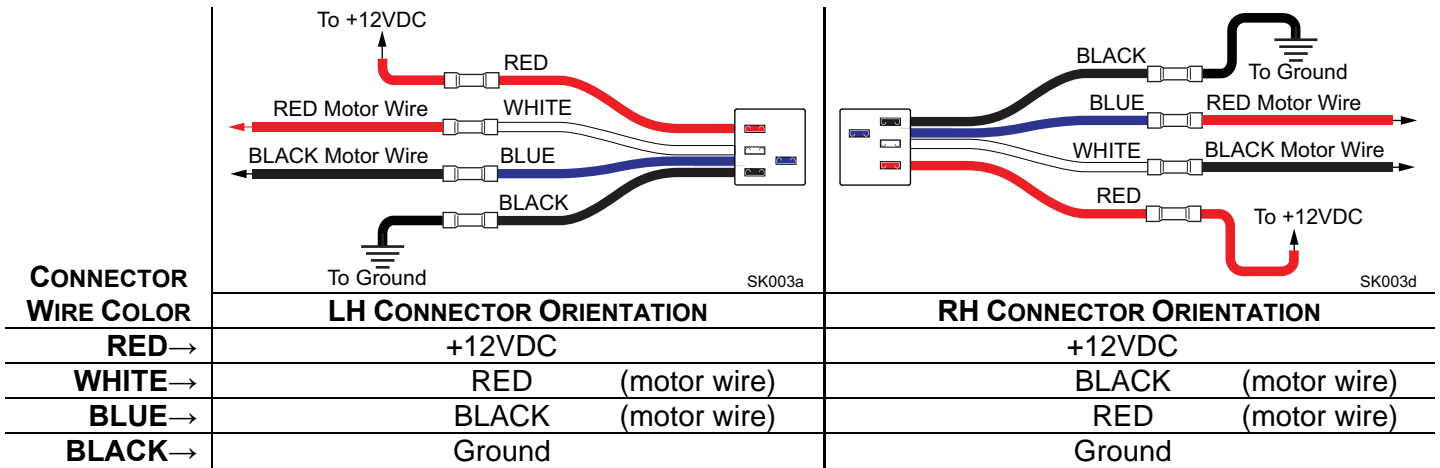

5. Run a minimum 14 awg wire from the power distribution panel (auxiliary battery circuit) or equivalent. The circuit should be protected by a 15-amp fuse.

6. Run a minimum 14 awg wire to system ground.

NOTE: If the wire run is 30 feet or longer, use 12awg wire to prevent voltage drop.

8. Route the two wires through the mounting hole. Butt splice the 12VDC wire to the RED connector wire. Butt splice the ground wire to the BLACK connector wire.

9. Attach the connector to the switch.

10. Restore power and test the switch operation.

11. If the awning operates opposite to the switch plate markings:

- Shut off power;
- Reverse motor wires connected to the blue and white connector wires;
- Restore power and test.

12. Push the wires, connector and switch into the mounting hole and secure the switch plate. Use two (2) #6 x 3/4" flat head screws.

FINAL ASSEMBLY

ATTACHING THE FASCIA AND BOTTOM COVER

1. Make sure the awning is completely closed.
 2. Insert the tab, on the fascia, under the arm base and rest it on the mounting plate.
 3. Check that the gap between the top of the fascia and the arm channel is approximately 1/8".
 - If the gap is too large or too small, set the fascia aside, loosen the mounting plate screws and adjust the mounting plate height as required. Tighten the screws and set the fascia in position.
 4. Place the bottom cover beneath fascia. Carefully tuck any wires into the bottom cover.
- NOTE:** There are tabs on the top of the cover to correctly align the bottom cover and fascia. The fascia should seat in the groove of the cover.
5. Attach the cover to the fascia with the supplied socket head screws using a 9/64" Allen wrench. The screws must go through the cover, the plate, and the fascia.
 6. Repeat for the other side.
 7. Verify proper installation by opening and closing the awning.

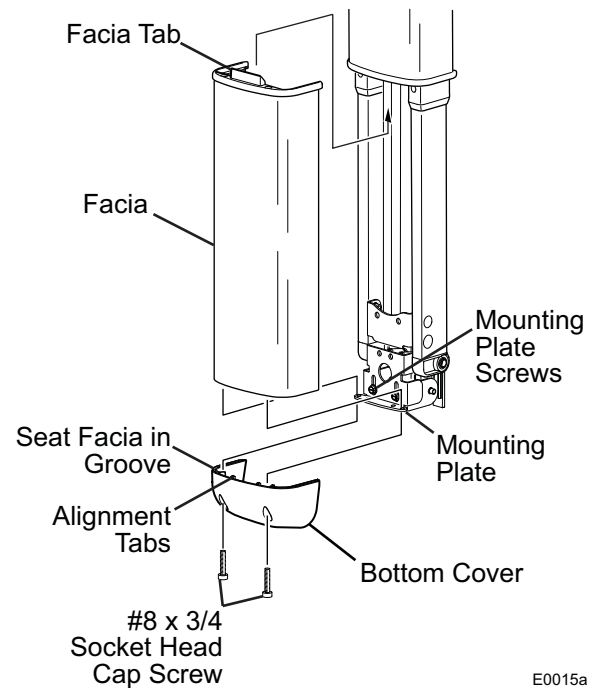

E0015a

SECURING THE FABRIC

1. Roll the awning in and out several times to make sure that the fabric is square on the rollbar.
2. Secure the canopy using one, #6 x 3/8" hex head screw at both sides of the awning.

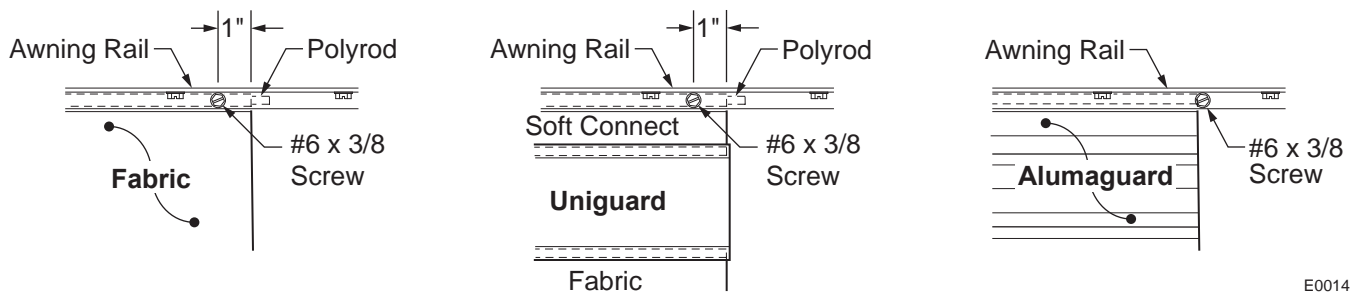

E0014

Figure 1. Securing the Fabric.

- 2.1 For vinyl awnings, place screw through awning rail, polyrod and canopy approximately 1" in from the end of the fabric.
- 2.2 For Uniguard awnings, place screw through awning rail, polyrod and the soft connect material approximately 1" in from the end of the fabric.
- 2.3 For Alumaguard awnings, place screw on the outer edge of the Alumaguard (not through the Alumaguard).

REMOVING THE TEMPORARY ASSEMBLY PINS

2 pins are inserted into the back of the left (idler) head for lateral stability during installation. Using a pair of pliers, remove and discard both pins.

NOTE: The awning will operate with the pins in place; for long term use, the pins must be removed to allow for climate variances.

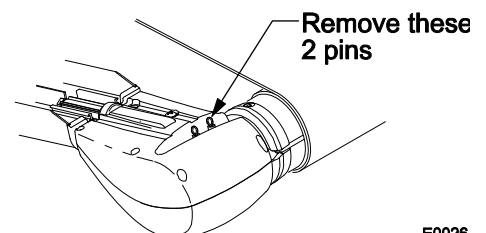

E0026

INSTALLING THE TRACTIONERS

The tractioners are used with the Alumaguard and Uniguard metal fabric wraps.

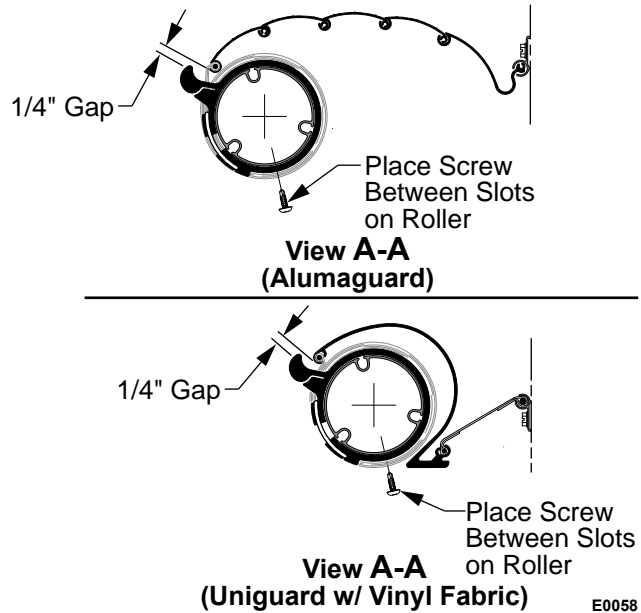
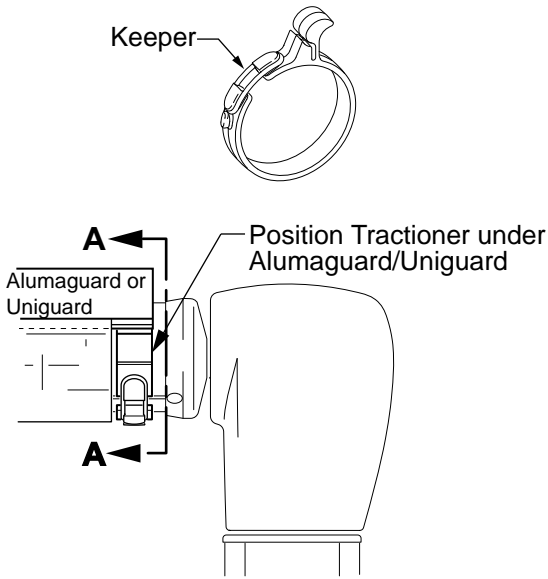

1. Partially extend the awning until the Alumaguard/Uniguard is extended as shown.
2. Unlock the keeper and wrap the tractioner around the roller tube.
3. Position the tractioner under the Alumaguard/Uniguard with a 1/4" gap between Alumaguard/Uniguard and tractioner. Lock the keeper.
4. Repeat for the other end of the rollbar.
5. Extend the awning to verify that the tractioners are lifting the metal wrap up and over the roller assembly.
6. To secure the tractioner, drill a 1/8" hole through the tractioner and rollbar, roughly center the hole between two slots of the rollbar.
7. Secure with one (1) #10 square drive screw.

OPTIONAL LED'S

Optional White LED light strips mounted in the roller tube are available.

NOTICES:

- a. **Do not route the wire over sharp edges or heat sources that can cut or fray the wires or wire insulation.**
- b. **Damage that is a result of improper routing may void warranty.**

WIRE ROUTING

1. For roller tube LED's:
 - 1.1 Route the LED canopy harness wires into the vehicle with the awning motor wires as shown.
 - 1.2 Allow a minimum 3" loop between the canopy and rear channel
 - 1.3 Secure the LED harness inside the channel with a quality silicone sealant.

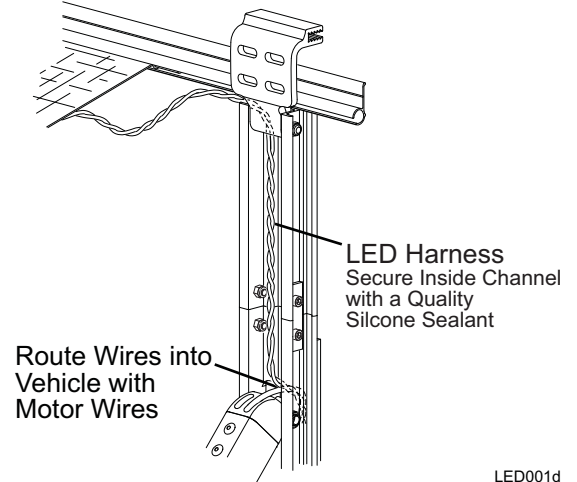

LED001d

SWITCH INSTALLATION

A single pole switch is required for the white LED installations.

For optional OEM RGB installations the single pole switch can be used as an optional power on/off control. This allows the lights to be shut off if the awning is retracted with the lights on.

NOTE: Installers may choose to furnish the control switch. The installation requires that the power line (+12VDC) be attached to a dedicated 2A circuit breaker or a 2A in-line fuse must be installed between the switch and power source. For easy access, locate the fuse close to the switch.

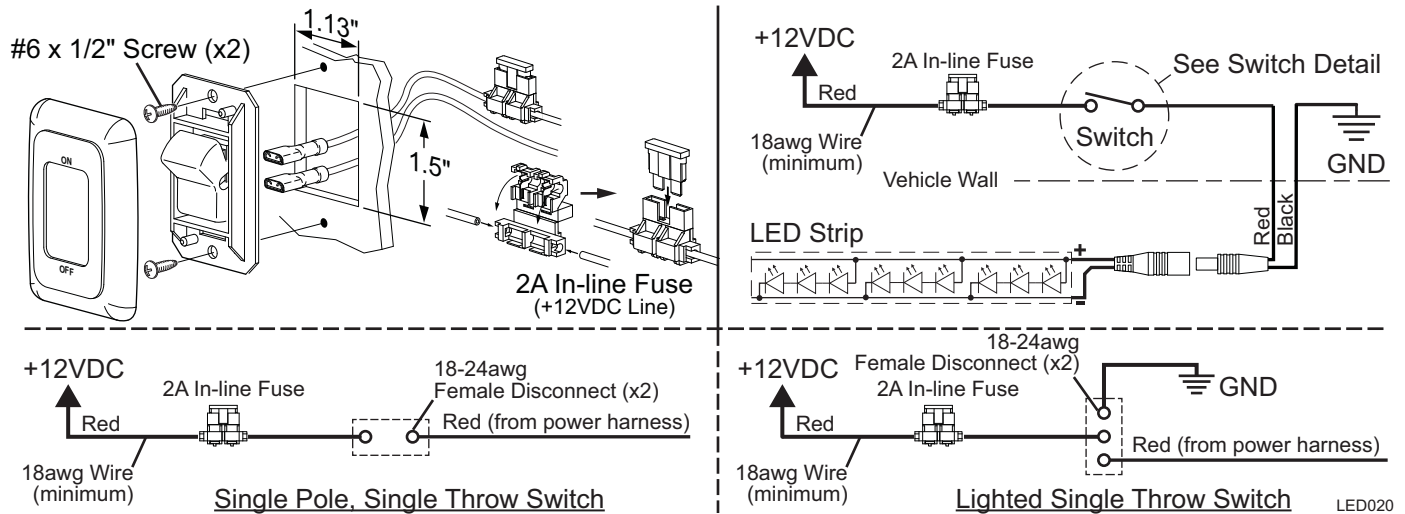

1. Determine the location of the switch.
2. At the switch location, cut a 1 1/8" x 1 1/2" hole.
3. Wire the switch as shown below. Wire terminals at the switch are .187, 18-24 awg female disconnects.

NOTE: Allow adequate slack in the 12VDC power line so that the in-line fuse (installed in step 4) can be accessed from behind the switch.

4. Install the in-line fuse:
 - 4.1. Near the switch, cut the red 12VDC power line to the switch. Do not strip the insulation.
 - 4.2. Insert a wire end into one of the wire channels until it butts up against the stop.
 - 4.3. Fold that half of the connector body over until the element contacts the wire. Use pliers to crimp the connector closed.
 - 4.4. Repeat for the second wire end.
 - 4.5. Slide the fuse into the fuse port. Ensure that is firmly seated.
5. Press the in-line fuse, wires and switch into the mounting hole. Secure the switch using two (2) #6 x 1/2" screws.
6. Snap the switch bezel over the switch frame.

ADJUSTING THE SPRING TENSION

It is possible to add spring winds to the assist spring in the idler head.

NOTE: Adding spring winds will decrease the retract time but will increase the extend time.

Adding Winds:

1. Open the awning a few inches to access the screws in the back of the idler head.
2. Remove the 5 small screws and the front cover.
3. Using a 3/8" wrench or socket, rotate the hex drive clockwise to add winds.

Tip: Make a mark on the hex drive and frame for reference to accurately count the number of winds.

4. **NOTE:** Do not exceed 15 complete winds. Adding more winds can deteriorate the awning's performance and operation.

Removing Winds:

1. Open the awning a few inches to access the screws in the back of the idler head.
2. Remove the 5 small screws and the front cover.
3. Firmly hold the roller tube in place.
4. Using needle nose pliers or a similar tool, pull the pawl down from the gear. The spring will unwind completely.

 **CAUTION** Keep hands and fingers away from gear and hex drive. When the pawl is pulled down, the spring will unwind quickly.

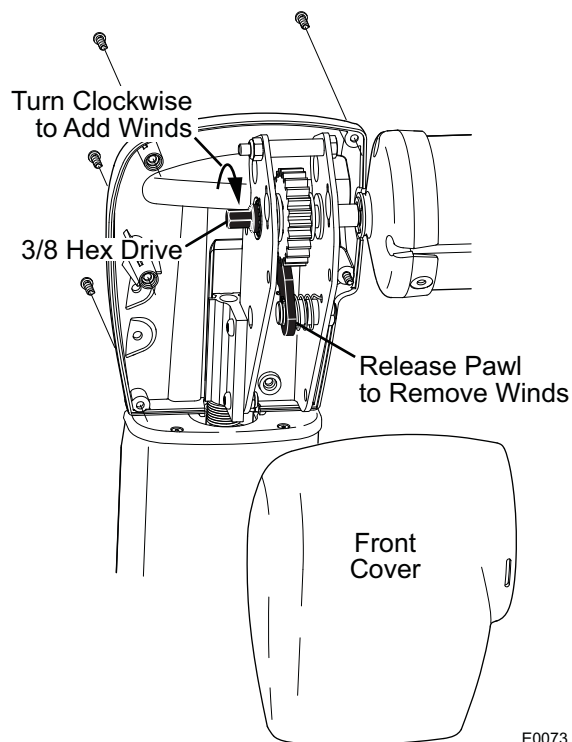

E0073