



# INSTALLATION MANUAL FREESTYLE EVOLUTION

## 12V MOTORIZED ROOF MOUNTED BOX AWNING

### RV



Read this manual before installing or using this product. Failure to follow the instructions and safety precautions in this manual can result in personal injury and/or cause the product to not operate properly.



### TABLE OF CONTENTS

<b>Product Overview</b> .....	<b>4</b>
Component Checklist.....	5
Freestyle RM Bracket Kits .....	5
<b>Installation</b> .....	<b>7</b>
Bracket Installation .....	7
Mounting the Awning .....	7
Jumping the Motor (with BT12) .....	7
<b>BT12 System Installation</b> .....	<b>8</b>
BT12 Control Module Installation.....	9
Awning Switch Installation .....	10
Awning Lights Switch Installation.....	10
Wiring Diagram .....	11
Setting the System into Pairing Mode.....	13
<b>Pitch Adjustment</b> .....	<b>14</b>
<b>Adjusting the Extend Limit</b> .....	<b>14</b>
<b>Manual Override</b> .....	<b>14</b>

## **NOTICES AND DISCLAIMERS**

### **TRADEMARKS**

The **Bluetooth**® word mark and logos are registered trademarks owned by the Bluetooth SIG, Inc. Use of such marks by Carefree of Colorado is under license.

Other trademarks and trade names are those of their respective owners.

### **STATEMENTS OF COMPLIANCE**

- BT12 Control Module
- BT Motion Sensor
- BT Remote

FCC and IC identification numbers are located on the exterior surfaces of the individual components.

#### ***FCC COMPLIANCE***

These devices comply with Part 15 of the FCC rules. Operation is subject to the following two conditions: (1) These devices may not cause harmful interference and, (2) These devices must accept any interference received, including interference that may cause undesired operation.

NOTE: This equipment has been tested and found to comply with the limits for a Class B digital device, pursuant to part 15 of the FCC rules. These limits are designed to provide reasonable protection against harmful interference in a residential installation. This equipment generates, uses and can radiate radio frequency energy and, if not installed and used in accordance with the instructions, may cause harmful interference to radio communications. However, there is no guarantee that interference will not occur in a particular installation. If this equipment does cause harmful interference to radio or television reception, which can be determined by turning the equipment off and on, the user is encouraged to try to correct the interference by one or more of the following measures:

- Reorient or relocate the receiving antenna.
- Increase the separation between the equipment and receiver.
- Connect the equipment into an outlet on a circuit different from that to which the receiver is connected.
- Consult the dealer or an experienced radio/TV technician for help.

Any changes or modifications not expressly approved by the party responsible for compliance could void the user's authority to operate the equipment.

#### ***IC COMPLIANCE***

These devices comply with Industry Canada license-exempt RSS standard(s). Operation is subject to the following two conditions: (1) These devices may not cause harmful interference and, (2) These devices must accept any interference received, including interference that may cause undesired operation.

Ces appareils sont conformes aux normes RSS exonérées de licence d'Industrie Canada. L'opération est soumise aux deux conditions suivantes: (1) Ces appareils ne doivent pas causer d'interférences nuisibles et, (2) Ces appareils doivent accepter toute interférence reçue, y compris les interférences pouvant entraîner un fonctionnement indésirable.

#### ***FCC/IC RADIATION EXPOSURE STATEMENT***

- BT12 Control Module
- BT Motion Sensor

This equipment complies with FCC and IC radiation exposure limits for an uncontrolled environment. The minimum distance between the radiator and people is designed to be 20cm when installed and operated.

Cet équipement est conforme aux limites d'exposition aux radiations FCC et IC pour un environnement non contrôlé. La distance minimale entre le radiateur et les personnes est de 20cm lorsqu'installé et utilisé.

- BT12 Remote

This equipment complies with FCC and IC radiation exposure limits for an uncontrolled environment. The minimum distance between the radiator and people is designed to be 5mm when operated.

Cet équipement est conforme aux limites d'exposition aux radiations FCC et IC pour un environnement non contrôlé. La distance minimale entre le radiateur et les personnes est de 5mm (à l'exclusion des extrémités: mains, poignets, pieds et chevilles) lors de l'utilisation.

## DISCLAIMERS

The BT12 Wireless Awning Control System and the Carefree Connects Mobile App are products of Carefree of Colorado, located in Broomfield, Colorado, USA. The information contained in or disclosed in this document is considered proprietary to Carefree of Colorado. Every effort has been made to ensure that the information presented in the document is accurate and complete. However, Carefree of Colorado assumes no liability for errors or for any damages that result from the use of this document.

The information contained in this manual pertains to the current components and software listed on the title page. Carefree of Colorado reserves the right to cancel, change, alter or add any parts and procedures, described in this manual, without prior notice.

Carefree of Colorado agrees to allow the reproduction of this document for use with Carefree of Colorado products only. Any other reproduction or translation of this document in whole or part is strictly prohibited without prior written approval from Carefree of Colorado.

## SERVICE AND SUPPORT

	<a href="http://www.carefreeofcolorado.com">www.carefreeofcolorado.com</a> <a href="http://www.carefreeofcolorado.com/carefreeconnects">www.carefreeofcolorado.com/carefreeconnects</a>
	<a href="mailto:customerservice@carefreeofcolorado.com">customerservice@carefreeofcolorado.com</a>
	Carefree of Colorado 2145 W. 6 <sup>th</sup> Ave. Broomfield, CO 80020

## SAFETY INFORMATION



This is the safety alert symbol. It is used to alert individuals to potential personal injury hazards. Obey all safety messages that follow this symbol to avoid possible personal injury or death.



Indicates a hazardous situation, which if not avoided, could result in death or serious bodily injury.



Indicates a hazardous situation, which if not avoided, may result in minor or moderate bodily injury.



Indicates a situation that may result in equipment-related damage.

### General Safety:



This product can expose you to chemicals including Di-isodecyl phthalate (DIDP), Vinyl Chloride and Formaldehyde, which are known to the state of California to cause cancer or birth defects or other reproductive harm. For more information visit [www.P65warnings.ca.gov](http://www.P65warnings.ca.gov)



Shock Hazard. Always disconnect battery or power source before working on or around the electrical system.



Always wear appropriate safety equipment (i.e. goggles).



Always use appropriate lifting devices and/or helpers when lifting or holding heavy objects.



When using fasteners, do not over tighten. Soft materials such as fiberglass and aluminum can be "stripped out" and lose the ability to grip and hold.

## PRODUCT OVERVIEW

The Freestyle Evolution Awning is a state of the art lateral arm awning. When retracted, the housing provides protection against the elements while the streamlined styling blends in with the vehicle appearance. The full tension canopy fabric allows the awning to be partially or fully extended for best shade coverage.

Each unit is equipped with lateral support arms. No vertical arms interfere with coach sidewalls, custom graphics or equipment that may be mounted on the sidewalls.

### Freestyle Awning Specifications:

- Fully retractable and self-storing;
- The sealed awning motor operates on standard 12VDC (range 10VDC to 14VDC);
- Case and frame are constructed of high-strength aluminum extrusions, protected with a polyester paint finish;
- BT12 Wireless Awning Control System is standard.

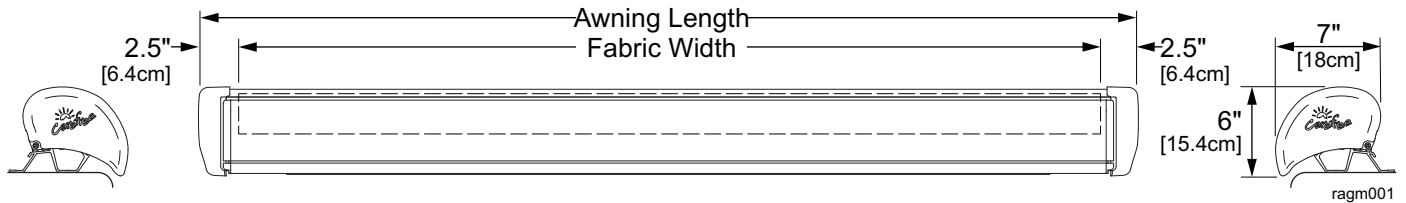

*NOTE: Dimensions shown are approximate. Dimensions may vary based on specific installations.*

### SPECIFICATIONS

Lengths:	centimeters	200 - 241	244 - 254	257 - 297	300 - 500
	inches	79 - 95	96 - 100	101 - 117	118 - 197
Extension:		152cm (60")	180cm (72")	200cm (80")	250cm (98")

### LEADING EDGE POSITION ACTUATION AND CONTROL

Power:	Lateral Arm Spring	Minimum Tension	Open
Position Control:	12V Motorized		
Controller:	BT12 Wireless Awning Control System		

### MOTOR SPECIFICATIONS

Motor Type:	Tubular		
Power:	12VDC	Minimum: 10VDC	Output: 30 Watts
		Nominal Current: 2.5Amps	Max Current: 14Amps (stall @ min voltage)
Power Source:	Motor and controls are routed and hardwired into the vehicle's 12V system		
Torque	Continuous: 6Nm/4.5 ft-lbs.		
Speed	24 rpm		

### COLORS AVAILABLE

Case	Satin, White or Black
Fabric: <sup>1</sup>	Vinyl or Woven Acrylic

**Special Note: Dimensions are provided in centimeters. Conversion formulas are provided below;**

$$\text{Inches} = \frac{\text{Centimeters}}{2.54} = \frac{\text{Millimeters}}{25.4}$$

$$\text{Centimeters} = \text{Inches} \times 2.54 \quad \text{Millimeters} = \text{Inches} \times 25.4$$

# COMPONENT CHECKLIST

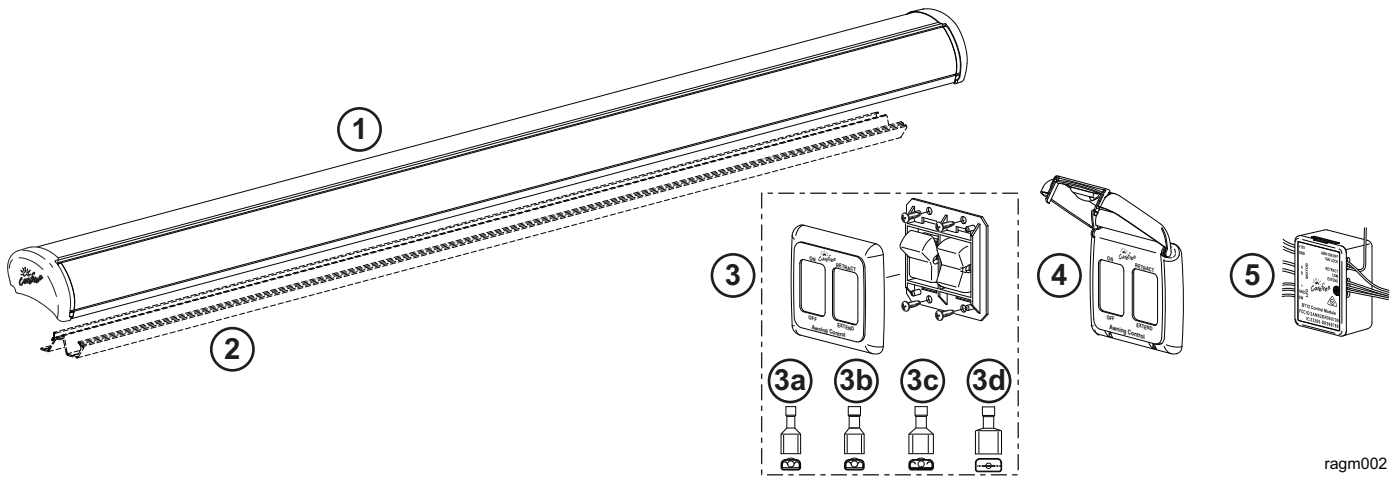

ragm002

☑ ITEM	DESCRIPTION	QTY	NOTE
<input type="checkbox"/> 1	Awning Assembly, Complete	1	
<input type="checkbox"/> 2	Mounting Bracket Ordered Separately, Refer to "Freestyle RM Bracket Kits"		
<input type="checkbox"/> 3	Switch Kit	1	
<input type="checkbox"/> 3a	Terminal, Female, .187	18-22 awg	3
<input type="checkbox"/> 3b	Terminal, Female, .187	14-16 awg	2
<input type="checkbox"/> 3c	Terminal, Female, .25	14-16 awg	1
<input type="checkbox"/> 3d	Terminal, Male, .25	14-16 awg	1
<input type="checkbox"/> 4	Covered Bezel, 2 Switch	1	2
<input type="checkbox"/> 5	BT12 Control Module	1	3

- NOTES:
- Specific awning configuration is specified at time of order, including awning length, fabric, color etc. check awning assembly against original purchase order.
  - The covered bezel (item 4) is optional and ordered separately. Refer to page 8 for information about NFPA 1192 RV Standard, Section 6.4.9 (Switch Installation Requirements).
  - The BT Motion Sensor is factory installed in the lead rail on the motor side.

## FREESTYLE RM BRACKET KITS

Bracket kits are ordered separately. Several types are available based on the application installation. Bracket mounting instructions are separate instructions that supplement this manual.

### BS0012

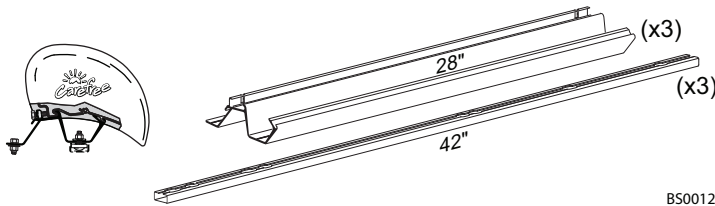

BS0012a

**Sprinter**  
4.5m & 5m

Mill Finish  
Bracket and Awning Hardware included  
Instruction Supplement: 052570-012

### BS0013

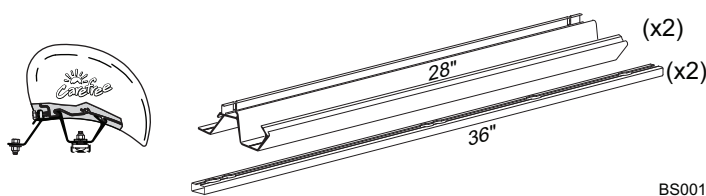

BS0013a

**Sprinter**  
4m and less

Mill Finish  
Bracket and Awning Hardware included  
Instruction Supplement: 052570-013

### BS0014

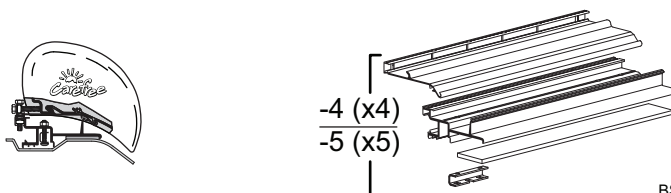

BS0014a

**Dodge ProMaster; Fiat Ducato**  
(-4) 4 Brackets 3.5m  
(-5) 5 Brackets 4m

Mill Finish  
Bracket and Awning Hardware included  
Instruction Supplement: 052570-014

**BS0016**

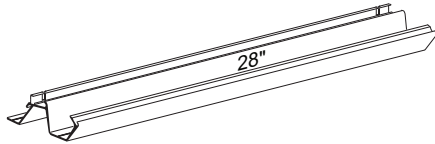

BS0016a

**Flat Roof**

- (-3) 3 Brackets 4m
- (-4) 4 Brackets 4.5m & 5m

Mill Finish  
 Bracket and Awning Hardware included  
 Instruction Supplement: 052570-016

**BS0017**

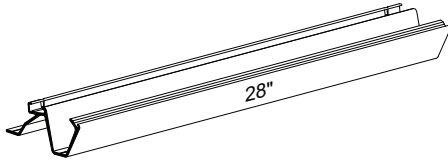

BS0017a

**Sprinter – No Rail**

- (-28-2) 2 Brackets up to 4m

Mill Finish  
 Bracket and Awning Hardware included  
 Instruction Supplement: 052570-017

**FULL LENGTH BRACKETS**

**BS0015**

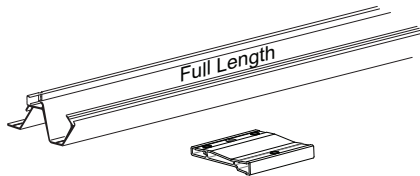

BS0015a

**Ford Transit**

- (-118-XX) Full Length 3m
  - (-138-ML) Full Length 3.5m
  - (-157-XX) Full Length 4m
- Mill (ML) or Black (JV) Finish  
 Bracket and Awning Hardware included  
 Instruction Supplement: 052570-015

**BS0018**

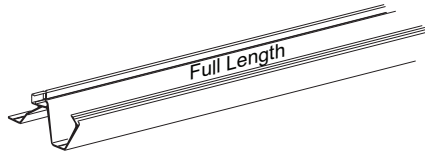

BS0018a

**Sprinter – No Rail**

- (-118-XX) Full Length 3m
  - (-157-XX) Full Length 4m
  - (-177-XX) Full Length 4.5m
- Mill (ML) or Black (JV) Finish  
 Bracket and Awning Hardware included  
 Instruction Supplement: 052570-018

**BS0019**

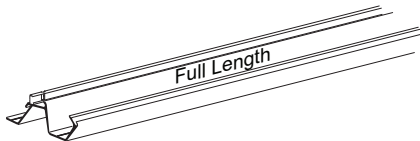

BS0019a

**Sprinter used w/ OEM Rail or Flat Roof**

- (-118-XX) Full Length 3m
  - (-157-XX) Full Length 4m
  - (-197-XX) Full Length 5m
- Mill (ML) or Black (JV) Finish  
 Bracket and Awning Hardware included  
 Instruction Supplement: 052570-019

**BS0021**

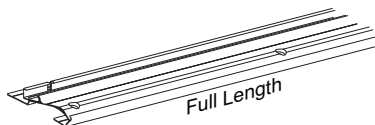

BS0021a

**Low Profile RM Mounting Bracket Kit**

- (-157-ML) Full Length 4m
- (-177-XX) Full Length 4.5m

Mill (ML) or Black (JV) Finish  
 Bracket and Awning Hardware included  
 Instruction Supplement: 052570-021

**BS0023**

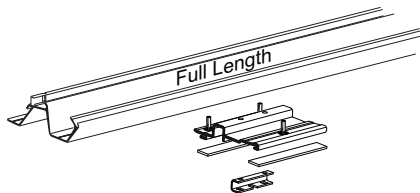

BS0023a

**Dodge ProMaster**

- (-157-XX) Full Length 4m

Mill (ML) or Black (JV) Finish  
 Bracket and Awning Hardware included  
 Instruction Supplement: 052570-023

## INSTALLATION

### BRACKET INSTALLATION

Install the mounting brackets according to the supplement instructions for the bracket kit.

**NOTE:** Install the brackets according to the bracket design. To correctly support the awning, the brackets must be positioned below the arm case knuckles. After the brackets are installed, go to "Mounting the Awning".

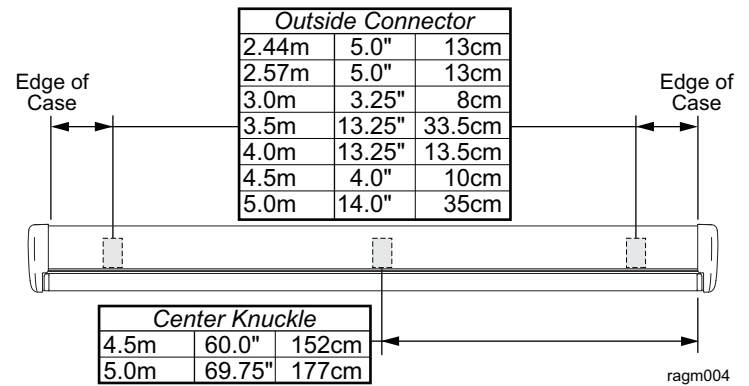

### MOUNTING THE AWNING

These steps apply to all bracket configurations.

1. If not previously done, in the rear track of the mounting plate(s), start three (3) M6 x 20 screws and square nuts through the holes. Do not tighten at this time.

**NOTE:** Locate 1 screw and nut at each end of the awning, the third screw and nut should be located near the center of the awning.

2. Lift and set the awning into the hooks of the mounting brackets. Pull the case forward to engage the brackets fully.
3. Horizontally center the awning on the brackets.
4. Tighten the rear screws. Torque to 10 ft-lbs [13.6 nm].
5. The motor and switch wires come out of the back of motor endcap. Drill a 5/16" [8mm] hole into the vehicle in the area shown.

**NOTE:** Locate the hole to avoid interior framing, cabinets and electrical components.

Ensure that the motor wires are accessible after routing.

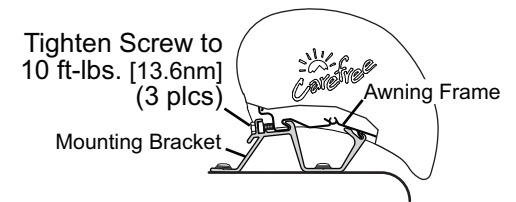
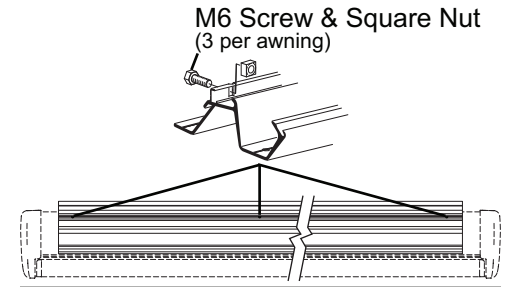

Align Hole with Edge of Endcap and Slightly Behind Awning

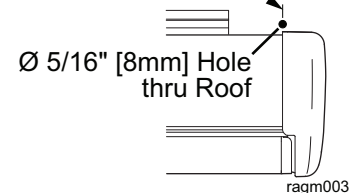

### Jumping the Motor (with BT12)

This method is used if the BT12 Wireless Awning Control System is to be used.

1. Temporarily connect the ends of the motor wires to a 12V-14V source (i.e. drill battery). If the awning does not begin to move, reverse the leads.
2. Remove the battery after the awning is open.

## **BT12 SYSTEM INSTALLATION**



**! WARNING** Shock Hazard. Always disconnect battery or power source before working on or around the electrical system.

**NOTICE** To comply with 2018 NFPA 1192 RV Standard, Section 6.4.7, switches must be mounted as follows:

For travel trailers and 5<sup>th</sup> wheels:

- a) Installed in a dedicated switch cabinet with a latching door; or,
- b) Installed with the optional covered bezel available from Carefree; or,
- c) Installed in a cabinet with a latching door where the switch is protected and CANNOT be activated by any items or cargo that may move or shift during transit; or,
- d) Installed with an interrupt circuit that disables awning extension when the vehicle is in motion (i.e. a relay tied into the parking brake or ignition that disconnects the BROWN extend wire).

For motorized coaches (Class A, Class B or Class C):

- a) Installed with an interrupt circuit connected to the "IGN LOCK" (green wire).

The BT12 module provides an ignition lockout option. When the "IGN LOCK" (green wire) is connected to the vehicle PCM or other switched source the following parameters are set:

- i) If Open = Awning Active
- ii) If tied to GND = RTL (Retract Then Lock) – Awning retracts, extend command disabled
- iii) If tied to +12Vdc = Standard – Extend command disabled

### **To Start:**

1. Determine the location for the awning switches, awning lights switch and BT12 control module.

**NOTE:** The BT12 control module leads are 6" in length. If the distance between the module and the switches is greater than 6", the installer must furnish splice wires for the extra distance. Use appropriate size wire gauges. Use appropriate sized butt splices to secure connections.

2. Route the motor cable and LED harness to the location of the module.



## BT12 CONTROL MODULE INSTALLATION

(Refer to the wiring diagram on page 11.)

**NOTICE** Do not mount the unit near heat producing elements such as LP appliances or engine exhaust components.

**NOTICE** For best reception, do not mount the unit near or on a metal surface.

1. Clean the mounting surface. The surface must be flat and clean for the mounting tape to properly adhere.
2. Remove the release paper from the tape on the back of the module and firmly press the module onto the mounting surface.

**NOTE:** The module may be oriented for best fit with access to the wire leads.

3. Attach the motor wires (refer to diagram for corresponding wire colors) to the module leads for the motor using 14-16awg butt splices.
4. Run a minimum 14 awg wire to chassis ground. Suitable ground would be the vehicle chassis or conductive structure connected to the chassis. Splice the wire to the module GND lead with a 14-16awg butt splice.
5. Run a minimum 14 awg wire from the power distribution panel (auxiliary battery circuit) or equivalent. The circuit should be protected by a 15-amp fuse. Splice the wire to the module +12V lead with a 14-16awg butt splice.
 

**NOTE:** If the wire run is 30 feet or longer for +12Vdc and/or GND, use 12awg wire to prevent voltage drop. Use the appropriate butt splices for the wire size.
6. Splice the Black wire from the LED Harness to the module LED GND lead (Black) with a 18-22awg butt splice.
7. Route the module LED + lead (RED) to the awning lights switch location. Use 20awg wire and 18-22awg butt splice to extend the lead as necessary.
8. Route the module IGN LOCK lead (Green) to the vehicle PCM or other switch source (used for ignition lockout).
9. Route the remaining wires (Violet, Gray, Yellow and Brown) to the location for the awning control switches. Use 20awg wires and 18-22awg butt splices to extend the leads as necessary.

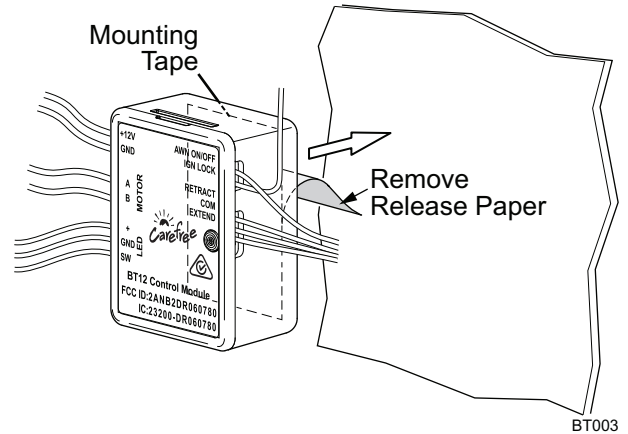

### AWNING SWITCH INSTALLATION

(Refer to the wiring diagram on page 11.)

1. At the switch location cut a 2.32" x 1.5" hole.
2. From the module, terminate the three (3) 20awg wires (Brown, Yellow and Gray) with .187, 18-20 awg female terminals. Attach to the EXTEND/RETRACT switch as shown in the wiring diagram.
3. From the module, terminate the Violet wire with a .187, 18-20 awg female terminal. Attach to the ON/OFF switch.
4. Run a minimum 14 awg wire to +12VDC. Terminate the wire with .187, 14-16 awg female terminal and connect to the second terminal of the ON/OFF switch.

**NOTE:** If the wire run is 30 feet or longer, use 12awg wire to prevent voltage drop. Use the appropriate wire terminals for the wire size.

5. Push the wires and switches into the hole then attach the switch frame using 4 #6 x 1/2" screws.
6. Snap the switch bezel over the switch frame.

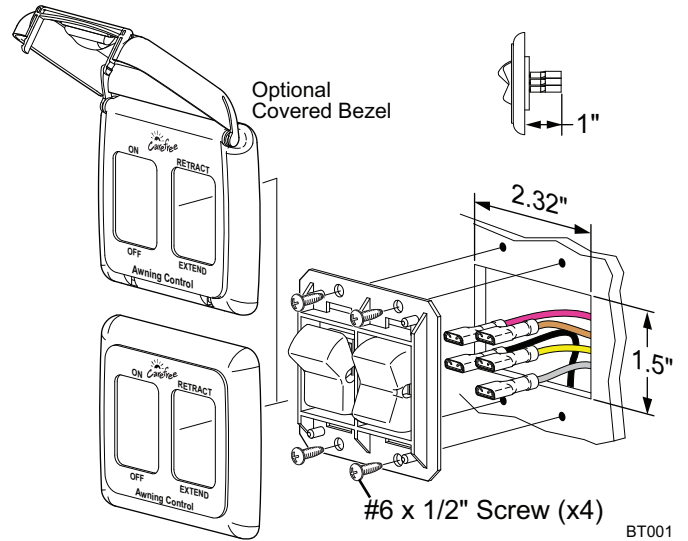

### AWNING LIGHTS SWITCH INSTALLATION

**NOTE:** Installers may choose to furnish the control switch or may wire directly to a multiplexing control center.

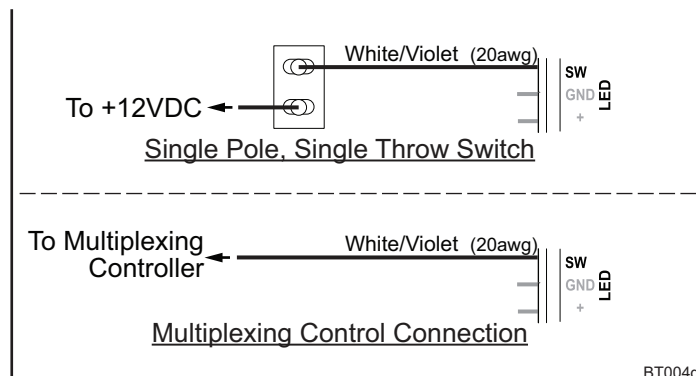
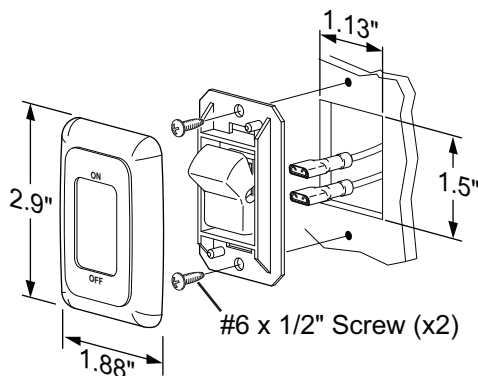

1. Determine the location of the switch.
2. At the switch location, cut a 1.13" x 1.5" hole.
3. Wire the switch as shown. Wire terminals at the switch are .187, 18-24 awg female disconnects.
4. Press the wires and switch into the mounting hole. Secure the switch using two (2) #6 x 1/2" screws.
5. Snap the switch bezel over the switch frame.

**WIRING DIAGRAM**

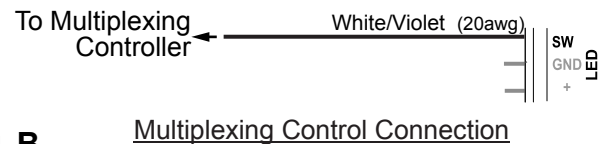
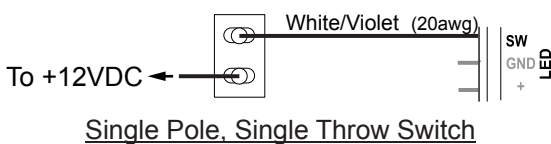
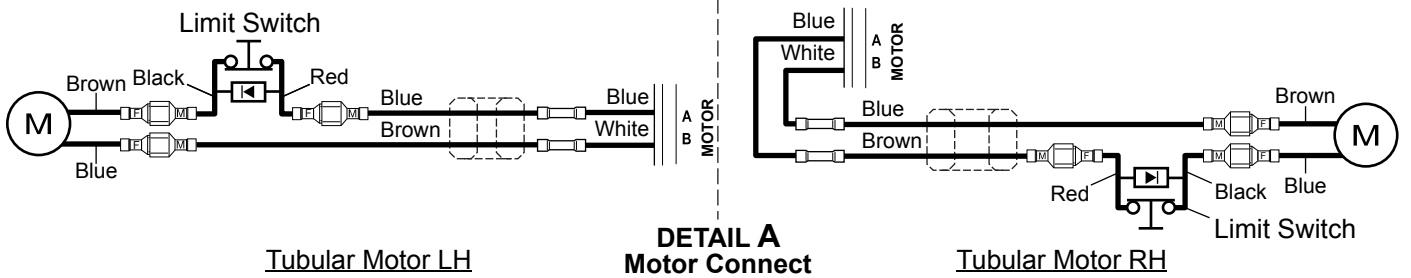
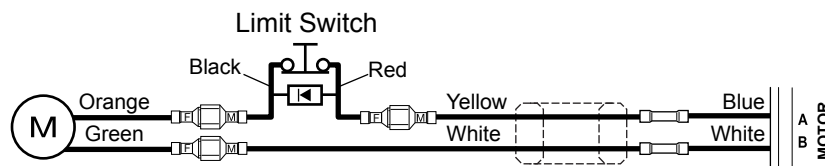
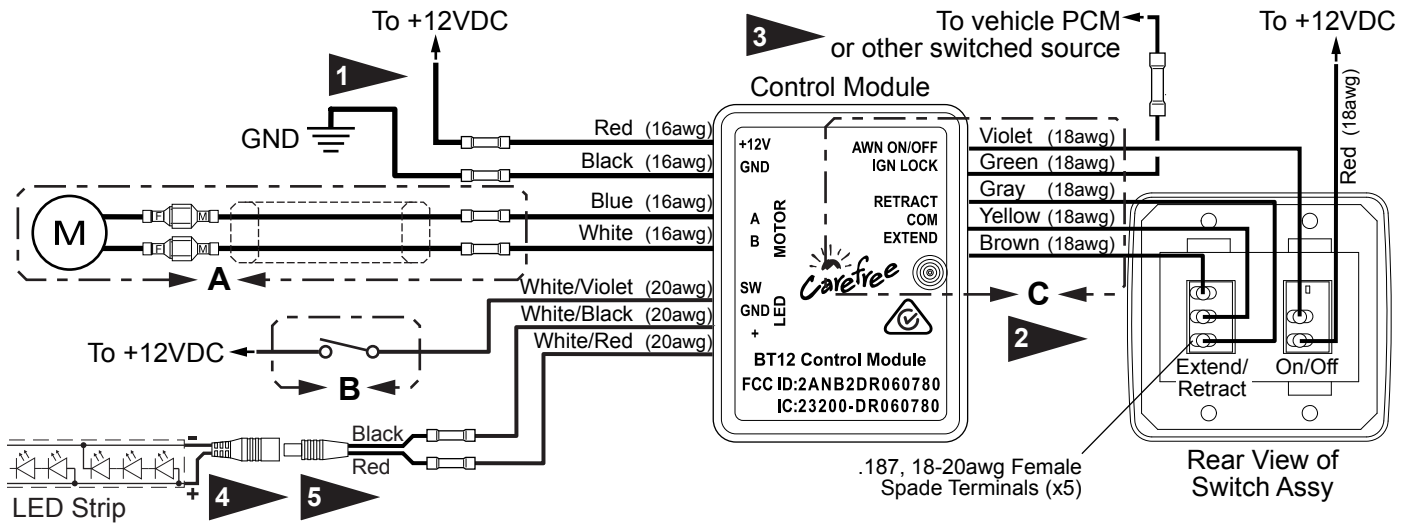

**DETAIL B Awning Lights Switch Options**

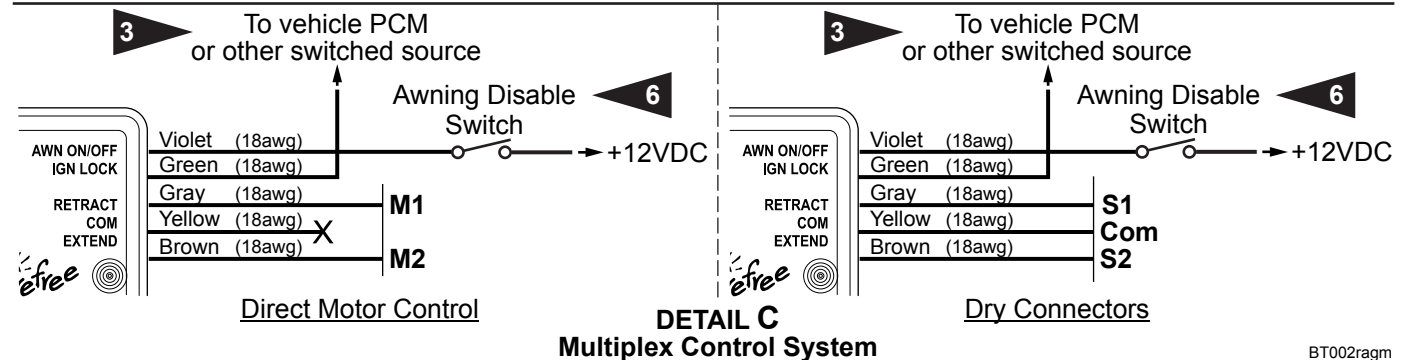

BT002ragm

- 
- 1** For GND, run a minimum 14 awg wire to chassis ground. Suitable ground would be the vehicle chassis or conductive structure connected to the chassis.  
For +12Vdc, Run a minimum 14 awg wire from the power distribution panel (auxiliary battery circuit) or equivalent. The circuit should be protected by a 15-amp fuse.  
**NOTE:** If the wire run is 30 feet or longer, use 12awg wire to prevent voltage drop. Use the appropriate wire terminals for the wire size.
- 
- 2** The BT12 module leads are 6" in length. If the distance between the module and the switch is greater than 6", the installer must furnish splice wires for the extra distance. Use appropriate size wire gauges. Use appropriate sized butt splices to secure connections.
- 
- 3** The BT12 module provides an ignition lockout option. When the "IGN LOCK" (green wire) is connected to the vehicle PCM or other switched source the following parameters are set:
- a) If Open = Awning Active
  - b) If tied to GND = RTL (Retract Then Lock) – Awning retracts, extend command disabled
  - c) If tied to +12Vdc = Standard – Extend command disabled
- 
- 4** The LED connection is optional to provide LED controls through the app for white LEDs only. White LEDs can also be installed per the standard LED installation without BT12 Controls. RGB lights must be installed per the standard RGB installation.
- 
- 5** Carefree LED lights uses a 2 amp circuit draw. The BT12 limits the output current to 2 amps. If using a different brand of high output LED's that draws more than 2 amps, the lights will flicker and not perform as expected.
- 
- 6** The awning disable switch is a single throw; single pole switch used with OEM Multiplexing Control Systems. Switch is furnished by installer.
-

## SETTING THE SYSTEM INTO PAIRING MODE

**NOTE:** Kits are paired at the factory for simplified installation. Separate components that are added or used for replacements must be paired to the existing control module.

**NOTICE** Ensure that the kits are kept together and not mixed with other kits. The pairings are unique to each control module.

**NOTE:** The illustration shows the standard Carefree switches. Some OEM's may choose to furnish their own switches or incorporate the power and Extend/Retract controls in a multiplexing control system. The following directions are valid for all configurations.

There are two methods to set the system into pairing mode.

### Using the Awning Retract Function:

1. Turn power to the awning ON.
2. Extend the awning. Note that the awning does not have to be opened completely.
3. Retract the awning.
4. When the awning is fully retracted, press and hold the retract switch for 3 seconds.



Press and hold the retract switch for 3 seconds after the awning has fully retracted.

BTA001b

### Using the Switches:

1. Turn the awning power switch to OFF.
2. Press and hold the extend switch.
3. While holding the extend switch, turn the power switch ON.
4. Continue to hold the extend switch for 3 seconds, then release.

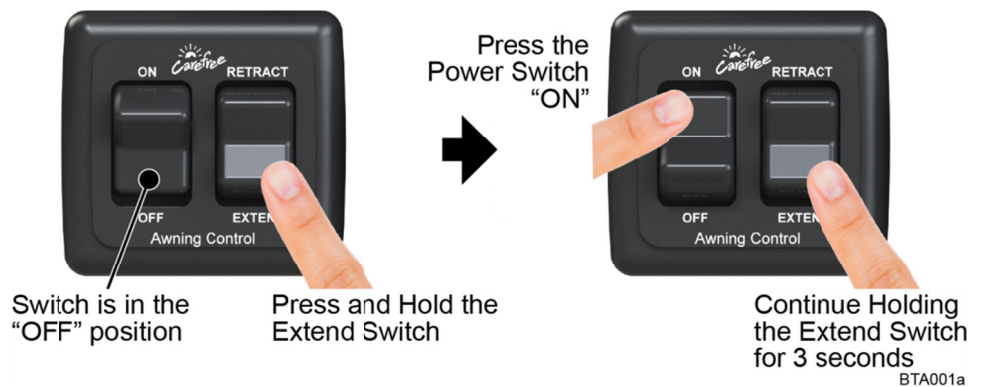

BTA001a

### NOTES:

- The awning will remain in pairing mode for 5 minutes.
- The BT12 control module will pair to the physically closest unpaired device first then go to working mode. Repeat the pairing for each additional device (the module remembers the devices that have been paired).
- Refer to the Carefree Connects Mobile App manual for setting up and pairing a smart device (such as a smart phone or tablet).
- Multiple devices can be paired to the awning up to a maximum of 8 peripheral devices.
  - Only one active BT Motion Sensor can be paired to the BT12 Control Module.
  - Only one active BT Remote can be paired to the BT12 Control Module.
  - Multiple mobile devices (smartphone or tablet) can be paired to the BT12 Module but only 1 can be active at a time.

The "BT12 Installation Manual" and "Carefree Connects Mobile App Manual" are available on-line at [www.carefreeofcolorado.com/connects](http://www.carefreeofcolorado.com/connects).

## PITCH ADJUSTMENT

The awning opens and closes with a steep pitch. On low profile vans, the leading edge of the awning may hit the top of the sliding door if the door is open while extending or retracting the awning. To prevent this, the lower limit of the pitch can be adjusted upwards.

1. Open the awning to access the screws located on the side of the arm case knuckles.
2. For Original Configurations:
  - 2.1. Using an 8mm allen wrench, loosen the 2 screws on the side of the case connector.
  - 2.2. Have a second person lift the lead rail to the desired height.
  - 2.3. When the pitch is set at the desired angle, tighten the screws. Torque to 50 ft-lbs.
3. For Current Configurations:
  - 3.1. Loosen the screw on the side of the case connector.
  - 3.2. Turn the 10mm (5mm allen wrench) clockwise to raise the pitch or counterclockwise to lower the pitch.  
*Tip: When raising the pitch have a second person lift up on the lead rail.*
  - 3.3. When the pitch is set at the desired angle, tighten the screw. Torque to 25-30 ft-lbs.
4. Repeat for each arm. Ensure that the lead rail is parallel with the awning case.

Loosen Screws to Adjust  
Tighten to 50 ft-lbs. When Finished

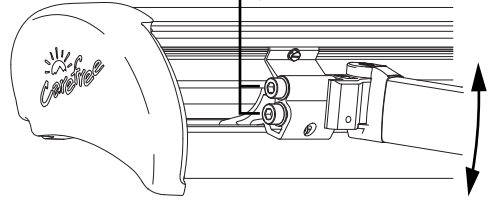

Original Configuration

Loosen Screw to Adjust  
Tighten to 25-30 ft-lbs. When Finished

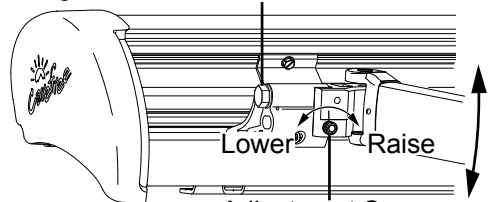

Adjustment Screw  
Current Configuration

ragm005

**NOTE:** The lead rail is self-adjusting. No adjustment is required to the lead rail when the pitch is changed.

## ADJUSTING THE EXTEND LIMIT

The extend limit switch disables the extend function when the awning is fully extended. This prevents the awning from overextending and can be adjusted so that the canopy is tight when the awning is extended.

The switch is located on the arm knuckle closest to the motor (i.e. right knuckle for RH motor, left knuckle for LH motor).

To adjust the extension:

1. Open the awning to access the switch.
2. Loosen the screw.
3. Move the switch toward the arm to decrease the extension.
4. Move the switch away from the arm to increase the extension.

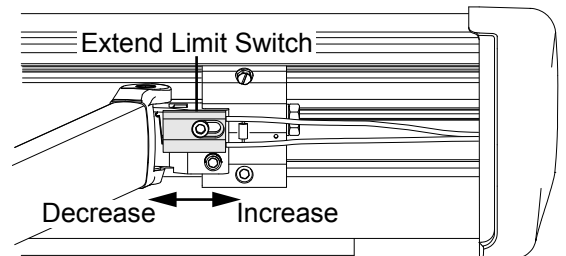

ragm007

## MANUAL OVERRIDE

If power to the vehicle is not available, the awning can be safely retracted using the manual override located on the idler end of the case.

**NOTE:** This procedure cannot be used to extend the awning.

1. Remove the outer endcap on the idler side and save.
2. Insert a 3/8" socket drive extension and handle into the square drive hole inside the inner end cap.
3. Turn the handle to match the direction arrows until the awning is retracted.
4. Replace the outer cap.

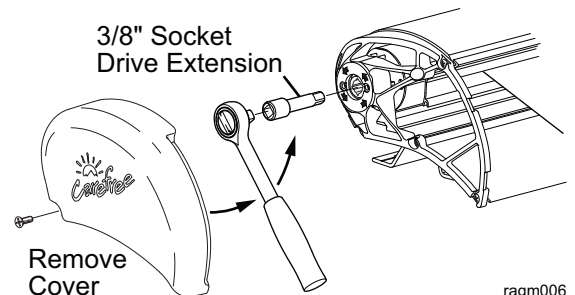

ragm006

**NOTICE** After closing the awning with the manual override, the lead rail may move out from the case 1/4" -1/2". This is normal and the awning is secure for travel until power is restored or repairs are completed. Do not attempt to force the lead rail in with the override, serious damage can occur to the awning.