



RV



Read this manual before installing or using this product. Failure to follow the instructions and safety precautions in this manual can result in personal injury and/or cause the product to not operate properly.



TABLE OF CONTENTS

Product Overview **3**

 Component Checklist.....4

 Freestyle RM Bracket Kits4

Installation **6**

 Bracket Installation6

 Mounting the Awning6

 Jumping the Motor (When Direct Response is Installed)6

 Jumping the Motor (without Direct Response)6

Switch Installation **7**

Optional LED Lighting..... **9**

 Switch Installation9

Pitch Adjustment..... **10**

Manual Override **10**

Setting the Motor Limits **11**

 Adjusting the OUT Limit Switch11

 Adjusting the IN Limit Switch11

PROPRIETARY STATEMENT

The Freestyle RM Awning is a product of Carefree of Colorado, located in Broomfield, Colorado, USA. The information contained in or disclosed in this document is considered proprietary to Carefree of Colorado. Every effort has been made to ensure that the information presented in the document is accurate and complete. However, Carefree of Colorado assumes no liability for errors or for any damages that result from the use of this document.

The information contained in this manual pertains to the current configuration of the models listed on the title page. Earlier model configurations may differ from the information given. Carefree of Colorado reserves the right to cancel, change, alter or add any parts and assemblies, described in this manual, without prior notice.

Carefree of Colorado agrees to allow the reproduction of this document for use with Carefree of Colorado products only. Any other reproduction or translation of this document in whole or part is strictly prohibited without prior written approval from Carefree of Colorado.

SAFETY INFORMATION



This is the safety alert symbol. It is used to alert individuals to potential personal injury hazards. Obey all safety messages that follow this symbol to avoid possible personal injury or death.



Indicates a hazardous situation, which if not avoided, could result in death or serious bodily injury.

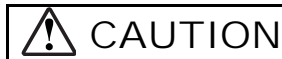

Indicates a hazardous situation, which if not avoided, may result in minor or moderate bodily injury.



Indicates a situation that may result in equipment-related damage.

General Safety:



This product can expose you to chemicals including Di-isodecyl phthalate (DIDP), Vinyl Chloride and Formaldehyde, which are known to the state of California to cause cancer or birth defects or other reproductive harm. For more information visit www.P65warnings.ca.gov



Shock Hazard. Always disconnect battery or power source before working on or around the electrical system.



Always wear appropriate safety equipment (i.e. goggles).



Always use appropriate lifting devices and/or helpers when lifting or holding heavy objects.



When using fasteners, do not over tighten. Soft materials such as fiberglass and aluminum can be "stripped out" and lose the ability to grip and hold.

PRODUCT OVERVIEW

The Freestyle RM Awning is a state of the art lateral arm awning. When retracted, the housing provides protection against the elements while the streamlined styling blends in with the vehicle appearance. The full tension canopy fabric allows the awning to be partially or fully extended for best shade coverage.

Each unit is equipped with lateral support arms. No vertical arms interfere with coach sidewalls, custom graphics or equipment that may be mounted on the sidewalls.

Freedom Awning Specifications:

- Fully retractable and self-storing;
- The sealed awning motor operates on standard 12VDC (range 10VDC to 14VDC);
- Case and frame are constructed of high-strength aluminum extrusions, protected with a polyester paint finish;
- Direct Response is standard.

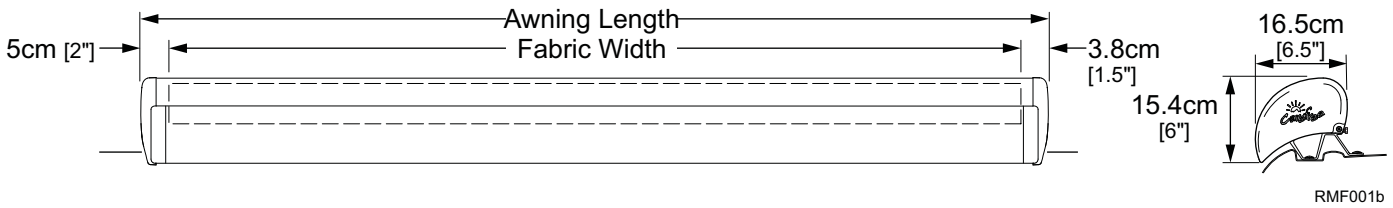

NOTE: Dimensions shown are approximate. Dimensions may vary based on specific installations.

SPECIFICATIONS

Lengths:	centimeters	200 - 241	244 - 254	257 - 297	300 - 500
	inches	79 - 95	96 - 100	101 - 117	118 - 197
Extension:		152cm (60")	180cm (72")	200cm (80")	250cm (98")

NOTE: Actual awning Length = 2.69" [6.8cm] shorter than stated length

LEADING EDGE POSITION ACTUATION AND CONTROL

Power:	Lateral Arm Spring	Minimum Tension	Open
Position Control:	12V Motorized w/ tubular motor		
Controller:	<u>Standard:</u> 12V Direct Response - Standard <u>Optional:</u> BT12 Wireless Awning Control System		

MOTOR SPECIFICATIONS

Motor Type:	Tubular		
Power:	12VDC	Minimum: 10VDC	Output: 30 Watts
	Nominal Current: 2.5Amps		Max Current: 14Amps (stall @ min voltage)
Power Source:	Motor and controls are routed and hardwired into the vehicle's 12V system		
Torque	Continuous: 6Nm/4.5 ft-lbs.		
Speed	24 rpm		

COLORS AVAILABLE

Case	Satin, White or Black
Fabric:¹	Vinyl

Special Note: Dimensions are provided in centimeters. Conversion formulas are provided below;

$$\text{Inches} = \frac{\text{Centimeters}}{2.54} = \frac{\text{Millimeters}}{25.4}$$

$$\text{Centimeters} = \text{Inches} \times 2.54 \quad \text{Millimeters} = \text{Inches} \times 25.4$$

COMPONENT CHECKLIST

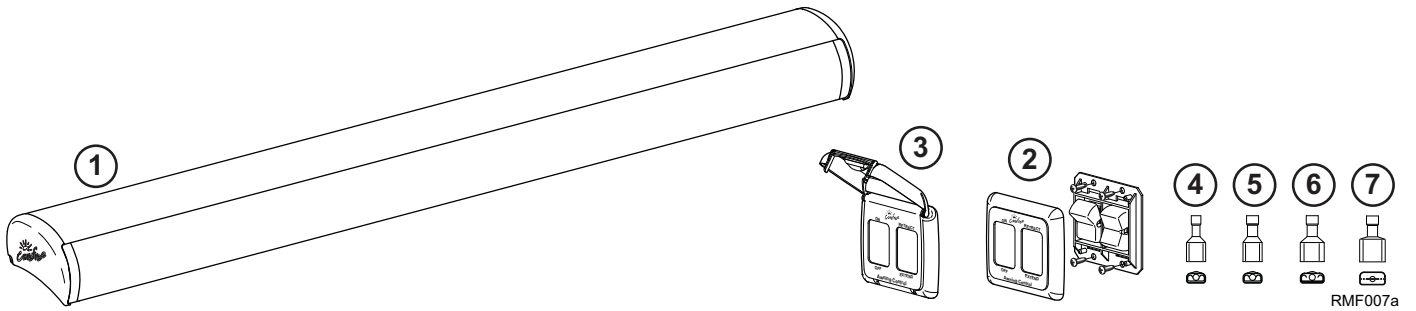

<input checked="" type="checkbox"/>	ITEM	DESCRIPTION	QTY	NOTE
<input type="checkbox"/>	1	Awning Assembly, Complete	1	
<input type="checkbox"/>	2	Switch Kit	1	3
<input type="checkbox"/>	3	Covered Bezel, 2 Switch	1	2
<input type="checkbox"/>	4	Terminal, Female, .187	18-22 awg	3
<input type="checkbox"/>	5	Terminal, Female, .187	14-16 awg	2
<input type="checkbox"/>	6	Terminal, Female, .25	14-16 awg	1
<input type="checkbox"/>	7	Terminal, Male, .25	14-16 awg	1

- NOTES:
- Specific awning configuration is specified at time of order, including awning length, fabric, color etc. check awning assembly against original purchase order.
 - The covered bezel (item 3) is optional and ordered separately. Refer to page 7 for information about NFPA 1192 RV Standard, Section 6.4.9 (Switch Installation Requirements).
 - Items 2 and 4 through 7 are used with the Direct Response system. Switches are included with BT12 Wireless Awning Control System kit when ordered.

FREESTYLE RM BRACKET KITS

Bracket kits are ordered separately. Several types are available based on the application installation. Bracket mounting instructions are separate instructions that supplement this manual.

BS0012

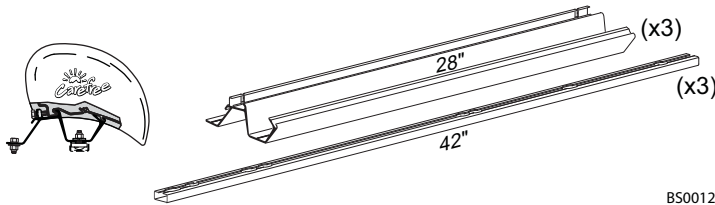

Sprinter
4.5m & 5m

Mill Finish
Bracket and Awning Hardware included
Instruction Supplement: 052570-012

BS0013

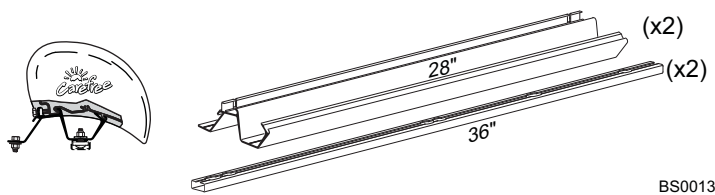

Sprinter
4m and less

Mill Finish
Bracket and Awning Hardware included
Instruction Supplement: 052570-013

BS0014

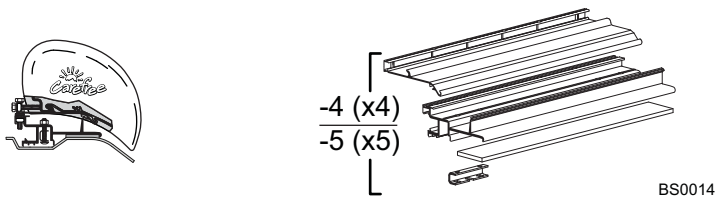

Dodge ProMaster; Fiat Ducato
(-4) 4 Brackets 3.5m
(-5) 5 Brackets 4m

Mill Finish
Bracket and Awning Hardware included
Instruction Supplement: 052570-014

BS0016

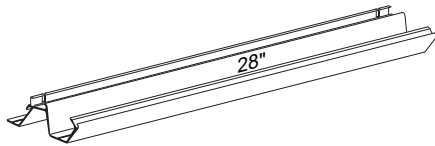

BS0016a

Flat Roof

- (-3) 3 Brackets 4m
- (-4) 4 Brackets 4.5m & 5m

Mill Finish
 Bracket and Awning Hardware included
 Instruction Supplement: 052570-016

BS0017

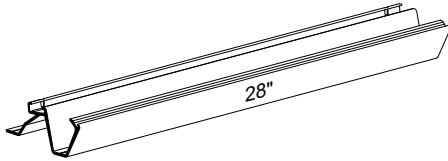

BS0017a

Sprinter – No Rail

- (-28-2) 2 Brackets up to 4m

Mill Finish
 Bracket and Awning Hardware included
 Instruction Supplement: 052570-017

FULL LENGTH BRACKETS

BS0015

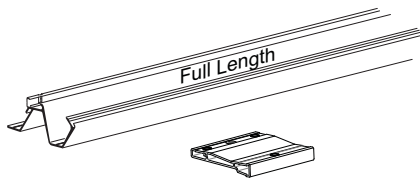
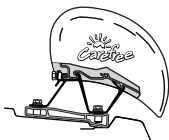

BS0015a

Ford Transit

- (-118-XX) Full Length 3m
 - (-138-ML) Full Length 3.5m
 - (-157-XX) Full Length 4m
- Mill (ML) or Black (JV) Finish
 Bracket and Awning Hardware included
 Instruction Supplement: 052570-015

BS0018

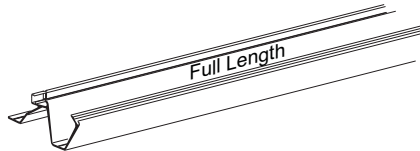

BS0018a

Sprinter – No Rail

- (-118-XX) Full Length 3m
 - (-157-XX) Full Length 4m
 - (-177-XX) Full Length 4.5m
- Mill (ML) or Black (JV) Finish
 Bracket and Awning Hardware included
 Instruction Supplement: 052570-018

BS0019

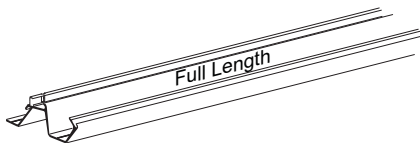

BS0019a

Sprinter used w/ OEM Rail or Flat Roof

- (-118-XX) Full Length 3m
 - (-157-XX) Full Length 4m
 - (-197-XX) Full Length 5m
- Mill (ML) or Black (JV) Finish
 Bracket and Awning Hardware included
 Instruction Supplement: 052570-019

BS0021

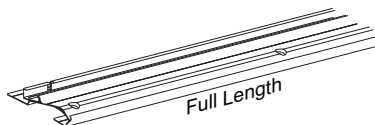

BS0021a

Low Profile RM Mounting Bracket Kit

- (-157-ML) Full Length 4m
- (-177-XX) Full Length 4.5m

Mill (ML) or Black (JV) Finish
 Bracket and Awning Hardware included
 Instruction Supplement: 052570-021

BS0023

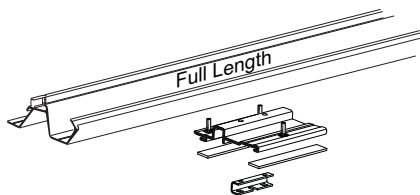

BS0023a

Dodge ProMaster

- (-157-XX) Full Length 4m

Mill (ML) or Black (JV) Finish
 Bracket and Awning Hardware included
 Instruction Supplement: 052570-023

INSTALLATION

BRACKET INSTALLATION

Install the mounting brackets according to the supplement instructions for the bracket kit.

NOTE: Install the brackets according to the bracket design. To correctly support the awning, the brackets must be positioned below the arm case knuckles. After the brackets are installed, go to "Mounting the Awning".

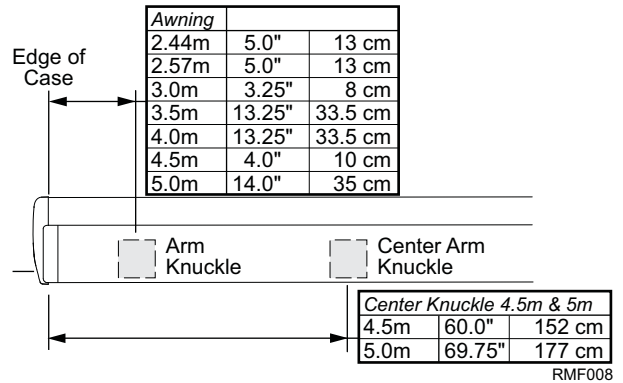

MOUNTING THE AWNING

These steps apply to all bracket configurations.

1. If not previously done, in the rear track of the mounting plate(s), start three (3) M6 x 20 screws and square nuts through the holes. Do not tighten at this time.

NOTE: Locate 1 screw and nut at each end of the awning, the third screw and nut should be located near the center of the awning.

2. Lift and set the awning into the hooks of the mounting brackets. Pull the case forward to engage the brackets fully.
3. Horizontally center the awning on the brackets.
4. Tighten the rear screws. Torque to 10 ft-lbs [13.6 nm].
5. The motor and switch wires come out of the back of motor endcap. Drill a 5/16" [8mm] hole into the vehicle in the area shown.

NOTE: Locate the hole to avoid interior framing, cabinets and electrical components.

Ensure that the motor wires are accessible after routing.

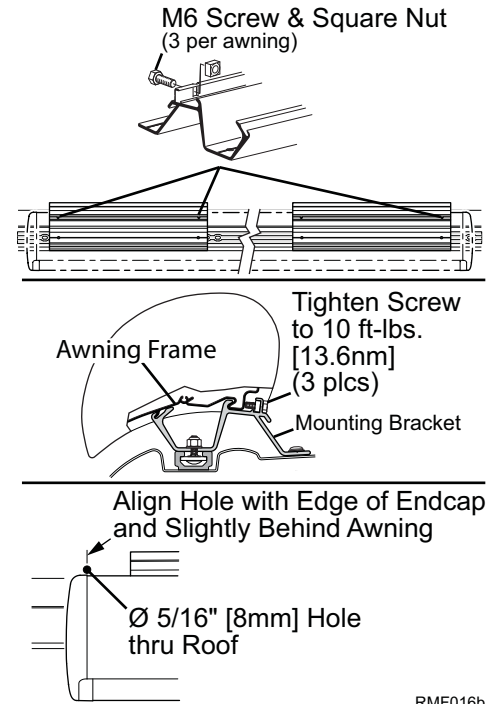

Jumping the Motor (When Direct Response is Installed)

If it is necessary to open the awning before the switch and wiring are complete, it is possible to jump the motor to open the awning.

1. Separate the wires at the end of the harness cable.
2. Attach the RED wire to the positive terminal of a 12-14V battery.
3. Attach the BLACK wire to the negative terminal of the battery.

NOTE: The awning circuitry includes "Reverse Polarity Protection" if the battery connections are accidentally reversed the awning electronics will not be damaged. If the wires are reversed, remove from the battery and reconnect in the correct order.

4. To extend the awning: Short and hold the BROWN and YELLOW wires together until the awning is open.
5. To retract the awning: Momentarily connect the GRAY and YELLOW wires together until the awning is closed.

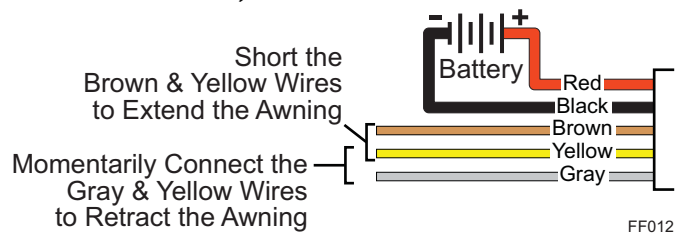

Jumping the Motor (with BT12)

This method is used if the BT12 Wireless Awning Control System is to be used.

1. Temporarily connect the ends of the motor wires to a 12V-14V source (i.e. drill battery). If the awning does not begin to move, reverse the leads.
2. Remove the battery after the awning is open.



If installing the BT12 Wireless Awning Control System use the wiring and setup instructions in "070029-001 BT12 Installation Manual".

Manual is available on-line at www.carefreeofcolorado.com/carefreeconnects.

SWITCH INSTALLATION



WARNING Shock Hazard. Always disconnect battery or power source before working on or around the electrical system.

NOTICE

To comply with 2018 NFPA 1192 RV Standard, Section 6.4.7, switches must be mounted as follows:

For travel trailers and 5th wheels:

- Installed in a dedicated switch cabinet with a latching door; or,
- Installed with the optional covered bezel available from Carefree; or,
- Installed in a cabinet with a latching door where the switch is protected and CANNOT be activated by any items or cargo that may move or shift during transit; or,
- Installed with an interrupt circuit that disables awning extension when the vehicle is in motion (i.e. a relay tied into the parking brake or ignition that disconnects the BROWN extend wire).

For motorized coaches (Class A, Class B or Class C):

- Installed with an interrupt circuit that disables awning extension when the vehicle is in motion (i.e. a relay tied into the parking brake or ignition that disconnects the BROWN extend wire or removes power from the awning controls).

- Determine the location for the switch.
 - There is 70" [180cm] of wire from the motor location. If the final routing to the switch location is greater than supplied cable, the installer must splice wire extensions to the cable wires.
 - For the motor wires use 16awg wire
 - For the switch wires use 20awg wire.
 - Wire and splices are furnished by the installer.
 - Location should provide the operator a view of the awning during operation.
 - At the switch location cut a 2-5/16" [5.9cm] x 1-1/2" [3.8cm] hole.
 - Route the cable from the awning through the hole.
 - Terminate the three (3) 22awg wires (Brown, Yellow, Gray) with .187, 18-20 awg female terminals. Attach to the EXTEND/RETRACT switch as shown in the wiring diagram.
 - Terminate the RED wire from the cable with a .187, 14-16 awg female terminal. Attach to one terminal of the ON/OFF switch.
 - Terminate the BLACK wire from the cable with a .25, 14-16 awg male terminal.
 - Run a minimum 14 awg wire to chassis ground. Suitable ground would be the vehicle chassis or conductive structure connected to the chassis. Terminate the wire with .25, 14-16 awg female terminal.
 - Connect the ground wire to the black wire from the cable.
 - Run a minimum 14 awg wire from the power distribution panel (auxiliary battery circuit) or equivalent. The circuit should be protected by a 15-amp fuse. Terminate the wire with a .187, 14-16 awg female terminal. Attach to one terminal of the ON/OFF switch.
- NOTE:** If the wire run is 30 feet or longer, use 12awg wire to prevent voltage drop. Use the appropriate wire terminals for the wire size.
- Push the wires and switches into the hole then attach the switch frame using four (4) #6 x 1/2" screws.
 - Snap the switch bezel over the switch frame.

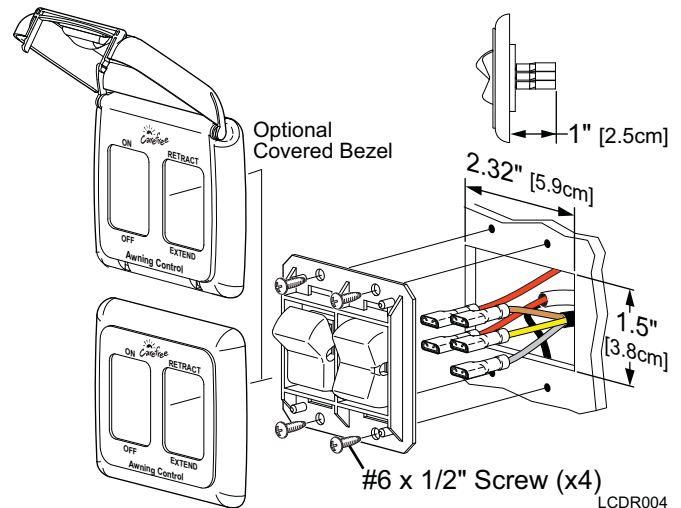

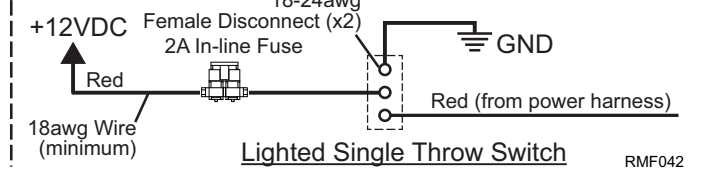
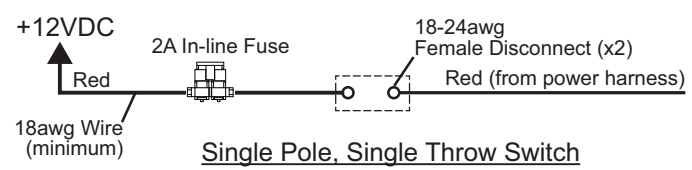
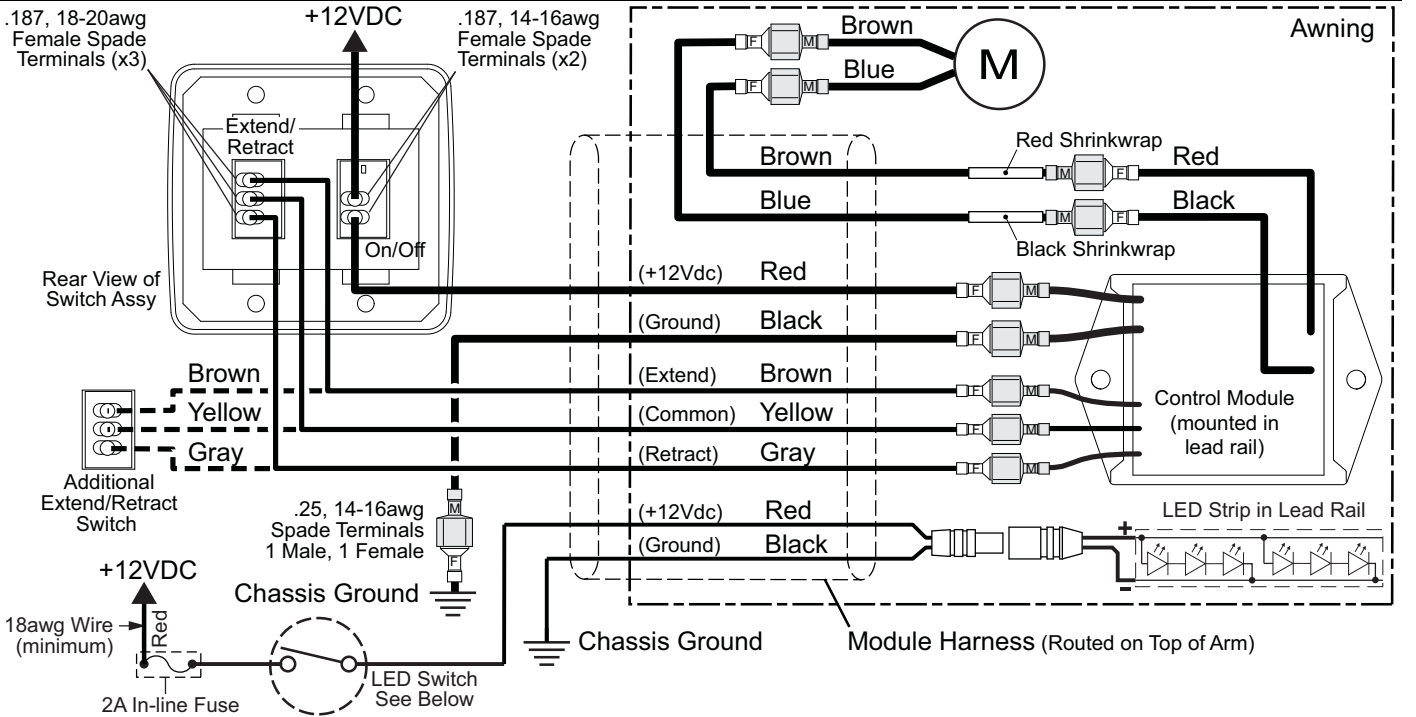

RMF042

OPTIONAL LED LIGHTING

Optional LED lighting may be mounted in the lead rail. The wiring runs along the top of the arm. The LED wire harness is incorporated as part of the sensor harness.

NOTICE The following information must be followed to avoid damage to the wiring during and after installation.

- The wire should be secured to the wall of the vehicle where it is exposed on the outside of the vehicle. Use a quality silicone sealant/adhesive.
- Do not route the wire over sharp edges or heat sources that can cut or fray the wires or wire insulation.
- Damage that is a result of improper routing may void warranty.

SWITCH INSTALLATION

NOTE: Installers may choose to furnish the control switch. The installation requires that the power line (+12VDC) be attached to a dedicated 2A circuit breaker or a 2A in-line fuse must be installed between the switch and power source. For easy access, locate the fuse close to the switch.

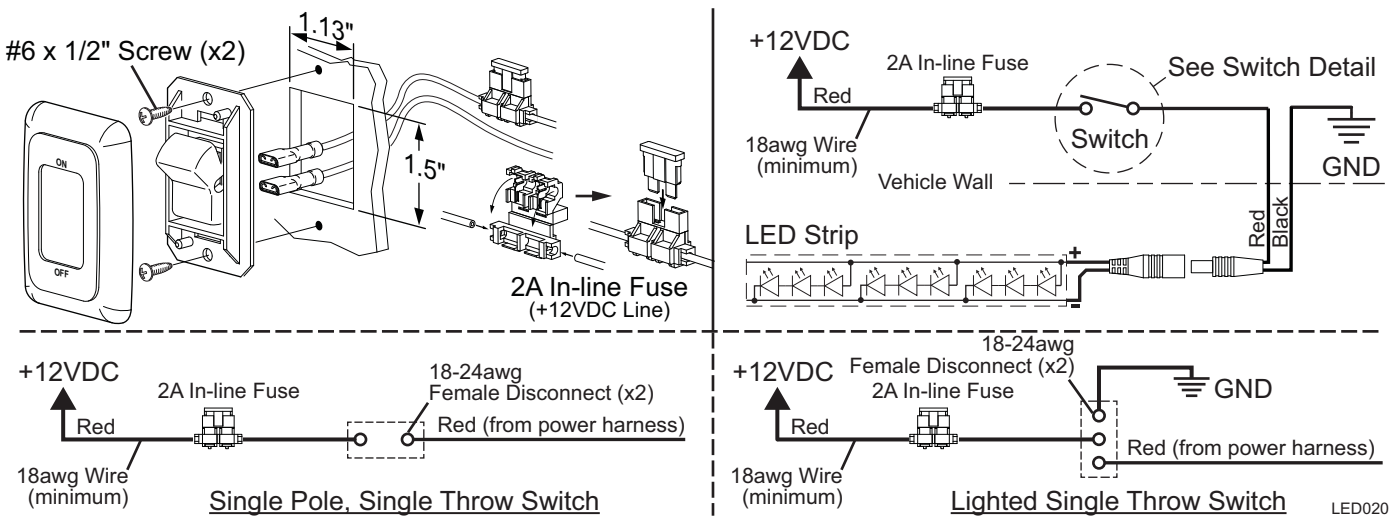

- Determine the location of the switch.
- At the switch location, cut a 1 1/8" x 1 1/2" hole.
- Wire the switch as shown below. Wire terminals at the switch are .187, 18-24 awg female disconnects.

NOTE: Allow adequate slack in the 12VDC power line so that the in-line fuse (installed in step 4) can be accessed from behind the switch.
- Install the in-line fuse:
 - Near the switch, cut the red 12VDC power line to the switch. Do not strip the insulation.
 - Insert a wire end into one of the wire channels until it butts up against the stop.
 - Fold that half of the connector body over until the element contacts the wire. Use pliers to crimp the connector closed.
 - Repeat for the second wire end.
 - Slide the fuse into the fuse port. Ensure that is firmly seated.
- Press the in-line fuse, wires and switch into the mounting hole. Secure the switch using two (2) #6 x 1/2" screws.
- Snap the switch bezel over the switch frame.

PITCH ADJUSTMENT

The awning opens and closes with a steep pitch. On low profile vans, the leading edge of the awning may hit the top of the sliding door if the door is open while extending or retracting the awning. To prevent this, the lower limit of the pitch can be adjusted upwards.

1. Open the awning to access the adjustment screws located on the arm case knuckles.
2. Have a second person lift up on the lead rail to relieve the pressure on the adjustment screws.
3. Using a 4mm allen wrench, loosen the top screw. Turn the bottom adjustment screw clockwise to raise the lead rail; turn the adjustment screw counterclockwise to lower the lead rail.
4. When the pitch is set at the desired angle, tighten the top screw.
5. Repeat for each arm. Ensure that the lead rail is parallel with the awning case.

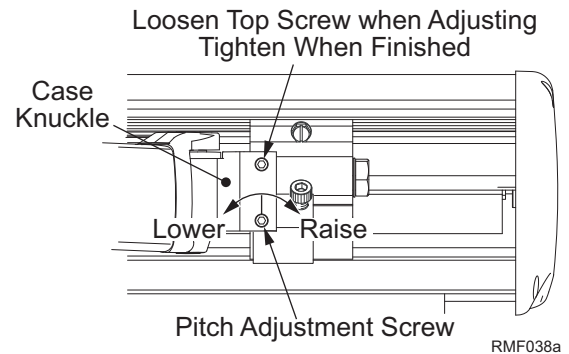

NOTE: No adjustment is required to the lead rail when the pitch is adjusted.

MANUAL OVERRIDE

If power to the vehicle is not available, the awning can be safely retracted using the manual override located on the idler (right) end of the case.

NOTE: This procedure cannot be used to extend the awning.

1. Remove the right outer endcap and save.
2. Insert a 3/8" socket drive extension and handle into the square drive hole inside the inner end cap.
3. Turn the handle clockwise until the awning is retracted.
4. Replace the outer cap.

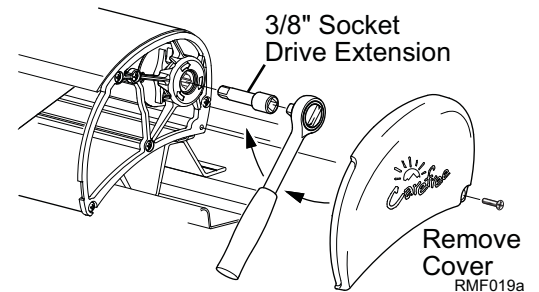

NOTICE After closing the awning with the manual override, the lead rail may move out from the case 1/4" -1/2". This is normal and the awning is secure for travel until power is restored or repairs are completed. Do not attempt to force the lead rail in with the override, serious damage can occur to the awning.

SETTING THE MOTOR LIMITS

The motor limit switches are preset at the factory for best operation of the awning. It may be necessary to reset the switches. The "out" limit switch is used to stop the motor when the awning is fully extended. The "in" limit switch is used to stop the motor when the awning is fully retracted.

The limit switches are located inside LH motor endcap. To access the switches:

- Remove the outer motor endcap
- Use a 4mm hex wrench through the holes of the inner endcap to adjust the switches.

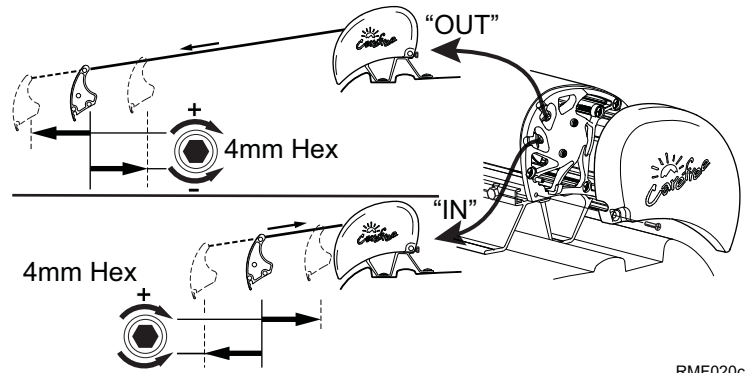

ADJUSTING THE OUT LIMIT SWITCH

The "OUT" limit switch stops the motor when the awning is fully extended.

1. Extend the awning out completely.
2. Confirm that the arms are fully extended. The motor should stop and the fabric should be tight. If the motor continues to run, the fabric will sag; or, if the motor quits before the arms are fully extended, it will be necessary to adjust the "OUT" limit switch.

NOTE: It is best to make the adjustments in increments of a single turn. 3 full turns of the screw equals approximately 2" of fabric extension.

3. If the fabric sags:
 - 3.1. Retract the awning until the fabric is tight then retract an addition 10"-12".
 - 3.2. Using a 4mm Allen wrench turn the "OUT" limit switch COUNTERCLOCKWISE to reduce the time the motor runs.
 - 3.3. Extend to confirm that the adjustment is correct.
 - 3.4. Repeat the procedure until the awning extends correctly.
4. If the arms do not extend completely:
 - 4.1. Retract the awning approximately 10"-12".
 - 4.2. Using a 4mm Allen wrench turn the "OUT" limit switch CLOCKWISE to increase the time the motor runs.
 - 4.3. Extend to confirm that the adjustment is correct.
 - 4.4. Repeat the procedure until the awning extends correctly.

ADJUSTING THE IN LIMIT SWITCH

NOTE: The "in" limit switch is not adjusted when the Direct Response system is installed. The system electronics monitors the motor and shuts the motor off when the awning is fully retracted.

If the "in" limit switch is accidentally adjusted, the motor may shut off before the awning is fully closed. If this occurs, turn the "in" adjustment screw clockwise. It is not necessary that the screw matches the closed position. The Direct Response electronics controls the closed position.